

New York Presbyterian Hospital Combined Heat and Power Project

Measurement and Verification Plan PON 914 – Category A



Prepared for:
New York Energy Research and Development & Authority
17 Columbia Circle
Albany, NY 12203-6399

On Behalf of:
Mrs. Jennifer Kearney-Herold
Director Energy Programs
New York Presbyterian Hospital

Prepared by:



Norgen Consulting Group, Inc.
127 Livingston Street, 2nd Floor
Brooklyn, NY 11201

Table of Contents

Hospital Background	3
System Overview	3
Heat Recovery and Displaced Thermal Equipment.....	4
Steam Production	4
Chilled Water	5
Facility Load Details.....	5
Electrical System	5
Natural Gas Service	6
System Schematic	8
Feasibility Study Findings	9
Data Collection and Monitoring	11
Monitoring Objectives	12
Monitoring Plan	13
Primary Objectives.....	13
Secondary Objectives.....	14
Monitoring Equipment.....	14
Appendix A – Metering Point Schematic	17

Hospital Background

In 1998, The New York Hospital merged with The Presbyterian Hospital to create New York-Presbyterian Hospital (NYPH). This event combined two world class academic health care institutions to create the largest and most comprehensive hospital in New York with over 13,000 employees and 2,400 patient beds. The hospital has over \$2.2 billion in annual revenue, five thousand physicians and delivers over 11,000 babies every year.

New York-Presbyterian Hospital (NYPH) is one of the most comprehensive university hospitals in the world, with leading specialists in every field of medicine. They are composed of two renowned medical centers, Columbia University Medical Center (Main Campus) and New York Weil Cornell Medical Center (Downtown Campus). They are affiliated with two Ivy League medical institutions, Columbia University College of Physicians & Surgeons and Weill Medical College of Cornell University.

NYPH is ranked higher in more specialties than any other hospital in the New York Area by U.S. News & World Report. In a recent survey of more than 250,000 leading doctors, more physicians from NYPH were named to the America's Top Doctors than from any other hospital in the nation.

The Downtown Campus, where this combined heat and power project (CHP) will be located, covers three city blocks between 68th Street and East 71st Street on the Upper East Side of Manhattan. The campus is nestled in between 1st Avenue and the East River.

System Overview

The CHP installation is a 7.5 MW cogeneration plant connected to the high tension service distribution system. The system consists of a gas turbine generator, duct burner and heat recovery steam generator (HRSG). The unit is a Taurus 70-T10301S Std., natural gas fuel turbine generator from Solar Gas Turbines.

The gas turbine generator set will be a single combustion turbine-based system consisting of a gas turbine and an induction generator. The set will have a nominal power generation capacity of 7.5 MW at ISO conditions. It will use natural gas as the primary fuel and No.2 fuel oil as back-up. The typical assembly is skid mounted with totally enclosed acoustical panels and is shown below in Figure 1 with no enclosure.

The unit will have "black-start" capability in order to operate in the event of utility power outage. However, there are no plans to export power to the grid. All generated power will be delivered to the hospital at 4160 volts. The steam produced by the CHP's heat recovery steam generator (HRSG) will be fed directly to the common steam header of the Central Utilities Plant.

The plant will include protective relays to isolate it from the Con Edison Grid. A G&W Current Limiting Protective Relay (CLiP) will protect the grid from fault currents from the machine.

Figure 1 Taurus 70-T10301S



Heat Recovery and Displaced Thermal Equipment

The hospital produces steam and chilled water with a central utilities plant (CUP) located in the Annex Building on 70th Street. All of the campus' electricity is currently supplied by energy marketers and delivered by Con Edison. Steam, chilled water and electricity are distributed throughout the campus in a vast piping and raceway network located beneath the buildings. Figure 2 provides an overview of the Downtown Campus. The CHP project will be located in the existing Central Utilities Plant; the Annex Building at 523 East 70th Street.

Steam Production

The existing boiler plant includes three, 125,000 lb/h boilers producing saturated steam at 212 °F and 185 psig. One boiler is used for standby. The boilers are dual fuel firing natural gas as the primary fuel and No.2 fuel oil as back-up. Natural gas is delivered by Con Edison at 60 psig and regulated to 14.9 psig for use in the boilers. Fuel oil is stored in six, 20,000 gallon cylindrical tanks located in separated vaults. All boilers are equipped with low NOx burners and permitted under New York State's Title V. Boilers are connected to a common breeching and exhausted into a 14 foot diameter chimney 383 feet above grade. Steam is used for heating as well as steam-driven turbine chillers and pumps. The steam peak occurs in the summer.

Figure 2 Downtown Campus Map

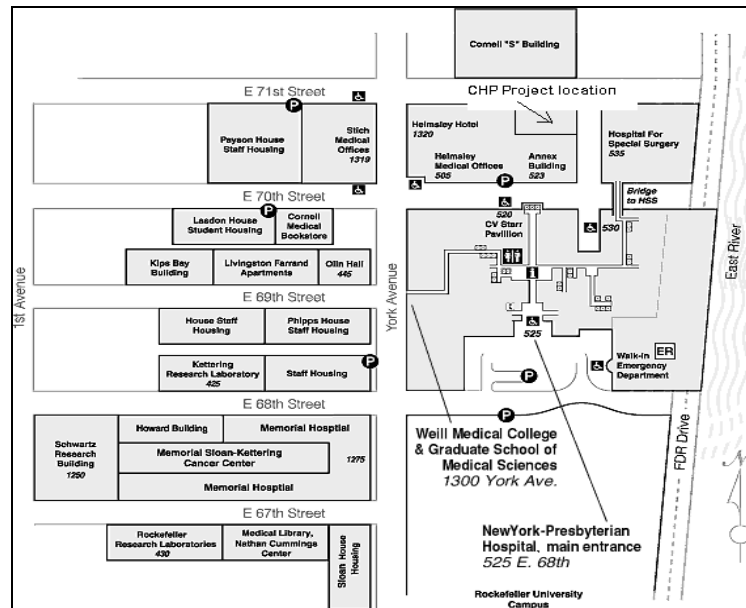

Chilled Water

The chiller plant is made up of four chillers with 10,400 tons connected capacity. Of the total connected capacity, 6,000 tons are steam driven and 4,400 tons are electrically driven. The table below, Figure 3, provides a list of the current chillers at the Central Utilities Plant, their rated and actual capacities and the energy source.

Figure 3 Current Installed Chillers for NYPH CUP

Chiller	Chiller Type	Nameplate Tonnage	Operating Tons	Cum Total
#3	Steam Turbine	2,200	2,200	2,200
#7	Steam Turbine	1,900	1,900	4,100
#9	Steam Turbine	1,900	1,900	6,000
#4	Electric	4,400	4,400	10,400

Facility Load Details

Electrical System

NYPH receives both High Tension (13.2 kV) and Low Tension (460 V) service from Con Edison. The high tension service switchgear and substation are located in the Baker Vault and are fed by six (6) Con Edison feeders coming from York Avenue via 68th Street. The 13.2 kV power is stepped down to 4,160 V and distributed to local load centers and electric motor driven chillers. The high tension service provides power to most of the campus and peaked at 11,198 kW on July 22, 2003.

The low tension service is supplied through six (6) feeders from the 71st Street. The peak demand for the low tension service was 5,186 kW in August 2003. Figure 4 shows the piping and raceway network throughout the campus. The high-tension service rate will be changed to Con Edison's SC-14RA Standby Service once the system becomes operational.

Natural Gas Service

Natural gas is delivered to the hospital from one meter on an interruptible gas delivery rate (SC12). The CHP plant will have a separate gas service on the SC9 - Rider H or SC2 - Rider H gas rate. NYPH is negotiating with Con Edison to receive natural gas at transmission pressure, however, a natural gas compressor is being installed in the event transmission pressure is not made available.

Figure 4 piping and raceways for Downtown Campus

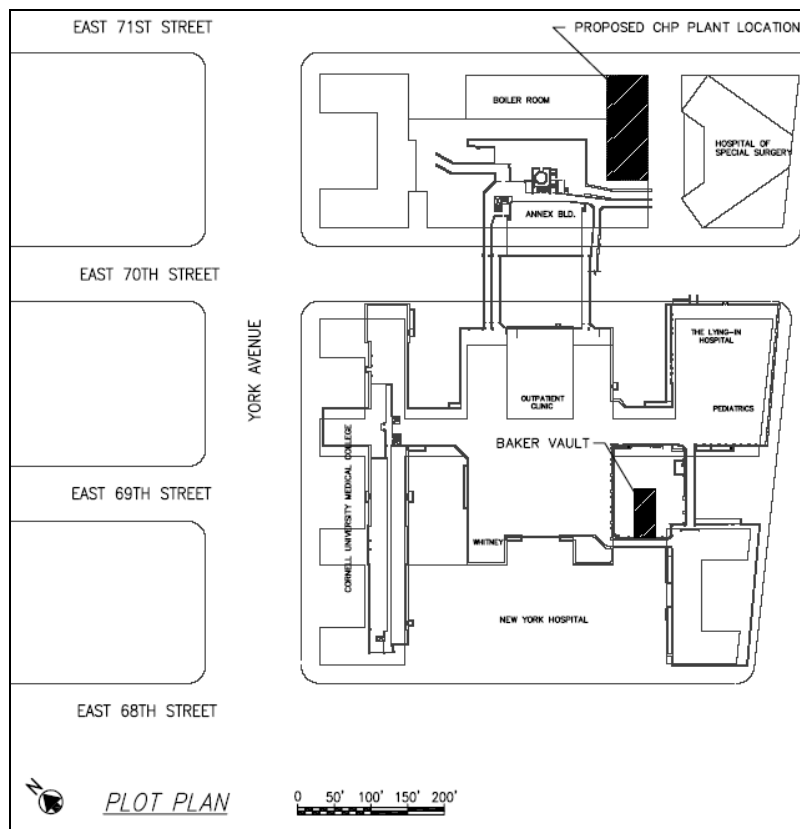

There are five (5) emergency generators located in the Central Utilities Plant rated at 900 kW and 460 Volts each. These generators are connected to the low tension system and are used for life safety as required by code.

The campus' annual steam consumption is shown in Figure 5. The electrical consumption on the high tension service is shown in Figure 6.

Figure 5 Annual Steam Consumption

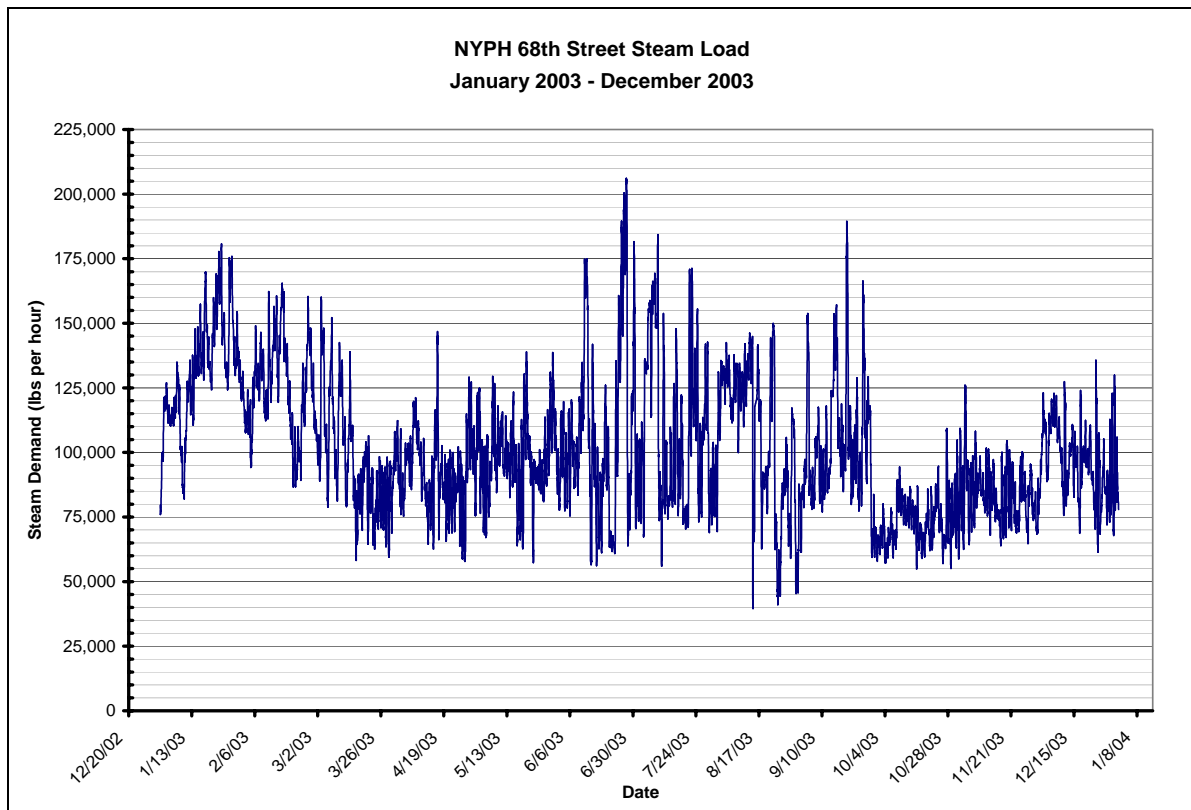
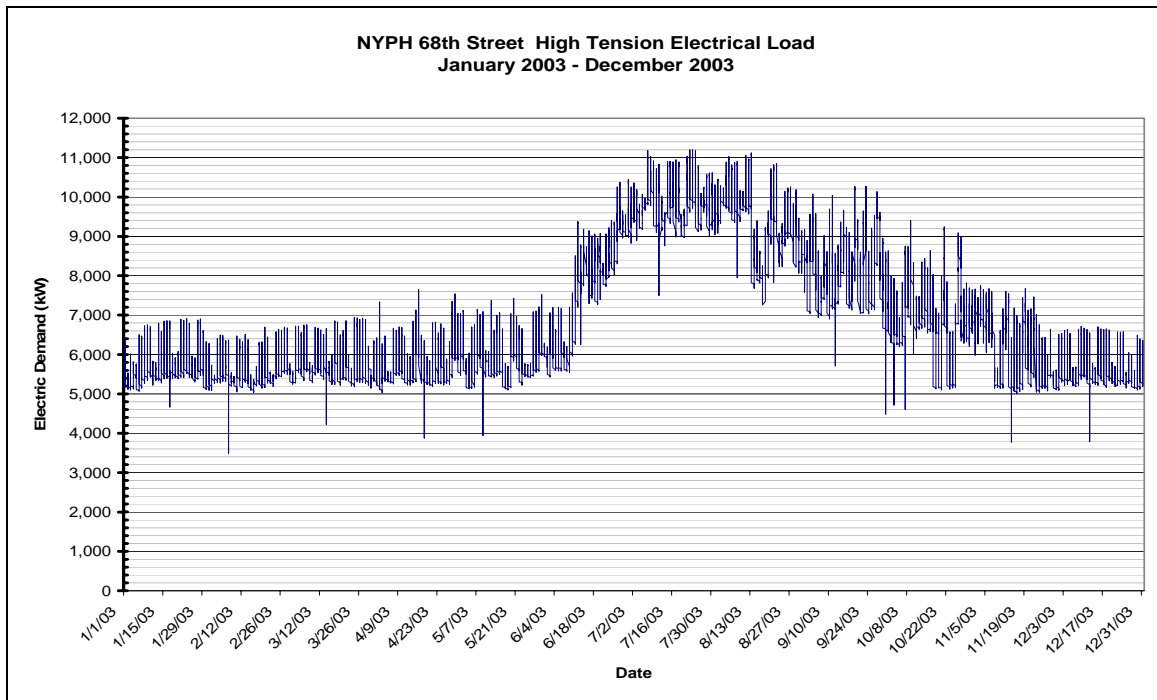

Figure 6 Annual Electricity Consumption of HT Service



System Schematic

A schematic diagram of the system is shown in Figure 7. The electricity generated by the CHP will be delivered to the hospital's high tension service entrance at 4,160 volts. This electricity will be provided to the common bus and used by the hospital's buildings. Steam will be created with a Heat Recovery Steam Generator (HRSG) and delivered to the common header of the hospital's Central Utilities Plant. If more thermal energy is required, a natural gas fired duct burner will be used to provide more steam to the header. A "dump" radiator will not be installed as part of this project.

The hospital has requested transmission pressure gas service for the project (300 psig.) If this delivery option is not made available, a natural gas compressor is being installed which will increase the parasitic load for the project.

Figure 7 CHP System Schematic

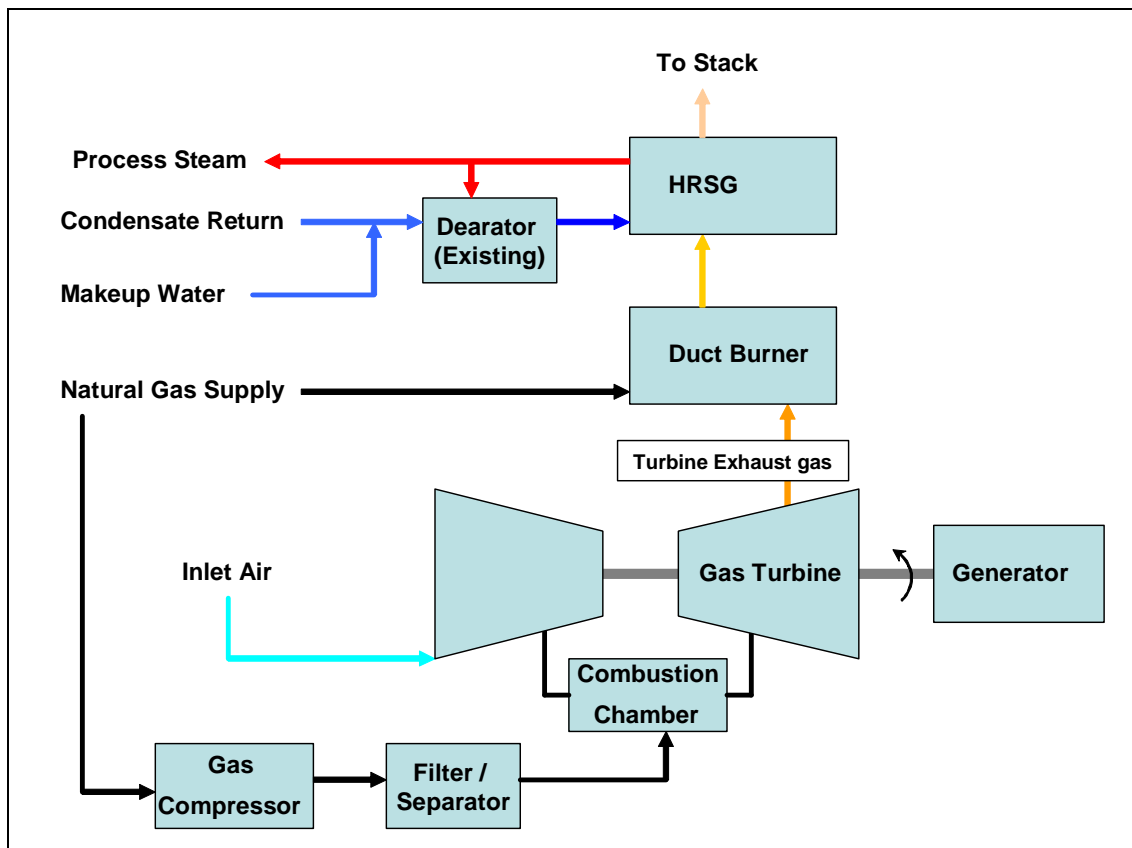

Feasibility Study Findings

A feasibility study was conducted in June 2004 for the project. In 2003, the hospital spent approximately \$11.7 million for purchased power, of which \$6.30 million was on the high tension service and \$4.78 was on the low tension service. They also spent \$7.41 million for fuel. The average cost of purchased high tension power was \$0.1039/kWh including all incentive programs. The study found that the CHP would produce high tension power at a net cost of \$0.06545/kWh which included the cost of fuel input, credit for steam by-product, and cost of operations and maintenance contracts on the system. It was estimated that the CHP system would produce annual energy savings of \$4.030 million. This savings was based on 8,760 hours of operation of the system, base year utility costs and projected loads for the campus.

The estimated installation costs for the system was \$16.9 million, or \$2,319 per kW of generating capacity. Required infrastructure improvements and chiller replacements costs were added to the estimate to bring the total cost to \$20.1 million.

The estimated base case 20 year life cycle cost was \$19.230 million with a break even at 7.1 years. Under the best case scenario, the 20 year life cycle cost was estimated at \$32.7 million with a break-

even of 5 years and the worst case scenario was a life cycle cost of \$5.1 million with a breakeven of 13 years.

Data Collection and Monitoring

A list of the point names and the data that will be collected is shown in Table 1. A schematic of the monitoring points is shown below in Figure 9. The schematic identifies the metering points required to meet NYSEERDA’s primary and secondary objectives.

Table 1 List of monitoring points

Point	Point Name	Data collected	Units
1	WG	Generator power output	kWh
2	WP	Parasitic loads	kWh
3	FGT	Natural gas to Turbine and Duct Burner	Therms
4	FSLH	Steam leaving CHP plant	BTU/h
5	FSLP	Steam leaving Central Utilities Plant	BTU/h
6	FGBP	Natural gas to Central Utilities Plant	Therms
7	FDBP	#2 Oil to Central Utilities Plant	BTU
8	WU	Utility supplied power	kWh
9	TAO	Outside air temperature and relative humidity	F, %
10, 11	TCHE, TCHL	Chilled water entering & leaving cooling coil	BTU/h

Figure 8 M&V Schematic

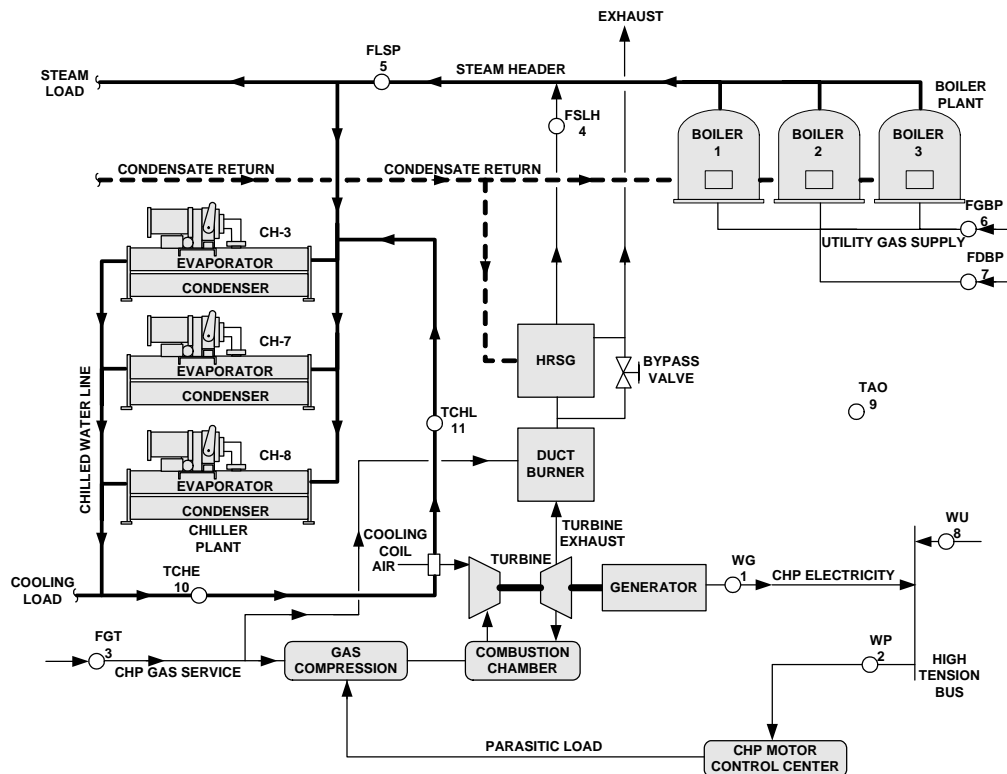

Monitoring Objectives

Table 1 lists the primary monitoring objectives of this M&V plan and Table 2 lists the secondary monitoring objectives.

Table 2 Primary Objectives

NYSERDA Monitoring Objectives

Primary - Required - Monitoring Objectives

No.	Objective	Data Point
1	Quantify the variation of DG CHP system power output, gas consumption, and efficiency over a wide range of annual operating conditions.	1, 3, 9
2	Quantify external parasitic loads (e.g. gas compressors, pumps, dump radiators, etc.)	2
3	Quantify the daily, weekly, monthly and annual variation of total facility power use (or power purchased from the utility) so that actual utility costs can be determined.	1+8
4	Determine the thermal loads imposed on the CHP system by the facility (or the useful thermal output supplied to the facility) to measure the total CHP efficiency of the system on a daily, monthly and annual basis. Quantify the variation of these loads with ambient conditions and operating schedules so the findings from this site can be extended to other climates.	$((4+1)-(2+11,12))/3$
5	Quantify the displaced fuel use on auxiliary equipment and systems to confirm the benefit of heat recovery	6, 7
6	Quantify the amount of available thermal energy that is unused or "dumped" by the CHP in order to demonstrate a system heat balance.	N/A

Table 3 Secondary Monitoring Objectives

Secondary - Optional - Monitoring Objectives

No.	Objective	Data Point
7	Determine the impact of generator operation on power quality in the facility (power factor, KVAR, frequency, total harmonic distortion.) Measure at generator output and/or main service entrance.	CHP
8	Collect diagnostic data to confirm the DG CHP system operates as expected and/or support of maintenance and operation activities.	commissioning report
9	Develop performance maps of the CHP equipment and components to verify manufacturer specifications	Solar Performance Test Report
10	Determine environmental emissions from DG CHP equipment to quantify net emissions impacts of the system.	Solar Performance Test Report

Monitoring Plan

Primary Objectives

Objective 1. *Quantify the variation of DG CHP system power output, gas consumption, and efficiency over a wide range of annual operating conditions.*

The electrical output (WG) of the generator will be provided by on-board metering equipment (point 1) and exported to the system's front end on a real time basis. It will be converted to MMBTU and stored hourly. The on-board metering equipment will also provide volts, amps, true power and power factor. The gas input for the generator (FGT) will be measured using utility supplied pulse outputs from the utility meter (point 3) and converted to MMBTU at the front end. These readings will be correlated to outdoor air temperature (TAO, point 9).

Objective 2. *Quantify external parasitic loads (e.g. gas compressors, pumps, dump radiators, etc.)*

The parasitic system loads (WP) will be collected from the motor control center (MCC) specifically installed for all parasitic loads (point 2) using a power meter (kW). The energy use will be calculated by averaging the kW reading hourly. A Btu meter or temperature in and out readings will be collected for the cooling coil to the make-up air intake for the CHP (point 11 and 12). This will quantify the parasitic cooling BTUs for the system.

Objective 3. *Quantify the daily, weekly, monthly and annual variation of total facility power use (or power purchased from the utility) so that actual utility costs can be determined.*

The power and energy consumed by the facility (kW) on the high tension service side will be collected from utility supplied pulse outputs (point 8). This data will be used to calculate total facility power by adding the kW and kWh from points 1 and 8.

Objective 4. *Determine the thermal loads imposed on the CHP system by the facility (or the useful thermal output supplied to the facility) to measure the total CHP efficiency of the system on a daily, monthly and annual basis. Quantify the variation of these loads with ambient conditions and operating schedules so the findings from this site can be extended to other climates.*

Temperature and flow meters (or BTU meters) will be installed at the output of the heat recovery steam generator to collect the thermal energy provided by the CHP on a real time basis and stored on an hourly basis (point 4). This meter will capture Btu's generated with and without duct firing. The thermal energy will be added to the electrical energy provided by the CHP (in Btu or MMBTU) to provide the total plant output. Parasitic electrical load and cooling coil load will be subtracted from this amount. The difference will be divided by the fuel input to the system (point 3) in order to calculate the overall efficiency of the system. This data will be correlated to outside conditions (point 9).

Objective 5. *Quantify the displaced fuel use on auxiliary equipment and systems to confirm the benefit of heat recovery.*

Pulse output data for the fuel input to the central utilities plant (points 6 and 7) will be continuously monitored to provide an indication of how much boiler gas use is displaced by heat recovery. The BTU information from the CHP steam output (as described above in Objective 4) will be converted to equivalent natural gas or #2 oil to quantify the amount of commodity saved.

Objective 6. *Quantify the amount of available thermal energy that is unused or "dumped" by the CHP in order to demonstrate a system heat balance.*

A "dump radiator" will not be installed as part of this project. Based on the thermal profile of the facility and the size of the plant, it is expected that all of the thermal energy for the CHP will be used by the facility.

Secondary Objectives

Objective 7. *Determine the impact of generator operation on power quality in the facility (power factor, KVAR, frequency, total harmonic distortion) measured at generator output and/or main service entrance.*

Power Factor, KVAR, frequency, etc., will be provided by the on-board metering equipment (point 1) and at the main bus.

Objective 8 and 9. Collect diagnostic data to confirm the DG CHP system operates as expected and/or support of maintenance and operation activities. Develop performance maps of the CHP equipment and components to verify manufacturer specifications.

Performance data for the CHP system will be provided by on-board monitoring systems. This data will be exported to the front end and collected for future reference.

Objective 10. *Determine environmental emissions from DG CHP equipment to quantify net emissions impacts of the system.*

Emissions data will be collected at project start-up by the commissioning agent and manufacturer. This data will be provided as part of the start-up or post-construction report.

Monitoring Equipment

The proposed metering points for the project is shown in Figure 9. Most of the data collected from these points will be forwarded to a control system "front-end." It is proposed that the front end will be accessible through the hospital's intranet. Data required by NYSERDA can be exported from this site to a public domain site.

Table 4 Monitoring Equipment

Point	Equipment	Data collected	Conversion (if required)
1	On-Board meter	kWh	3412 Btu/kWh
2	Power Meter	kW	kWh=avg kW*1 hour, 3412 Btu/kWh
3	Gas Meter Pulses (utility provided)	Pulses	X pulses = Y therms, 100,000 BTU/Therm
4	Flow meter & temperature sensors	Flow and Temperature	BTU/h=[Flow rate (GPM) X 500 X (T _{out} -T _{in})]
5	Flow meter & temperature sensors	Flow and Temperature	BTU/h=[Flow rate (GPM) X 500 X (T _{out} -T _{in})]
6	Gas Meter Pulses (utility provided)	Pulses	X pulses = Y therms, 100,000 BTU/Therm
7	Flow meter	GPM	BTU = GPM*15 (mins)*140,000 BTU/Gallon
8	kW pulses (utility provided)	Pulses	X pulse = Y kW, BTU/h=kW*3412
9	Air Temperatuer Sensor	Air Temperature and relative humidity	
10, 11	BTU Meter	Flow, T _{in} and T _{out}	BTU/h=[Flow rate (GPM) X 500 X (T _{out} -T _{in})]

The overall plant efficiency will be calculated using the following formula:

$$(1) \quad N = (\text{CHP Power (1)} + \text{CHP steam (4)} - \text{CHP parasitic load (2)} - \text{CHP cooling (10\&11)}) / \text{CHP gas input (3)}$$

The contribution of the CHP to the facilities electrical requirement will be calculation using Equation (2):

$$(2) \quad \% \text{ kW contribution} = \text{CHP kW (1)} / [\text{Facility kW (8)} + \text{CHP kW (1)}]$$

The contribution of the CHP thermal output to the facility's total thermal requirement will be calculated using Equation (3):

$$(3) \quad \% \text{ Thermal} = \text{CHP BTU (4)} / [\text{Facility thermal (6 and/or 7)} + \text{CHP thermal (4)}]$$

Savings generated from the operation of the CHP system will be calculated using the following formulas:

$$(4) \quad \text{Average } \$/\text{kWh} = \text{Total metered cost/facility use (8)}$$

- (5) kWh savings = Average \$/kWh X Net CHP kWh (1-2)
- (6) Average \$/BTU = Total metered BTU / (facility BTU – CHP BTU)
- (7) Cost savings = Average \$/BTU X CHP BTU

Appendix A – Metering Point Schematic

