

**Joanne M. Mahoney**  
County Executive

**Patricia M. Pastella, P.E., BCEE**  
Commissioner

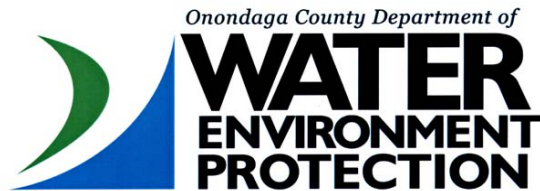

**MEASUREMENT AND VERIFICATION  
(M&V) PLAN  
FOR  
METROPOLITAN SYRACUSE  
WASTEWATER TREATMENT PLANT  
ADG-105N**

June 15, 2009

*Submitted to:*

**New York State Energy Research and Development Authority**  
17 Columbia Circle  
Albany, NY 12203-6399

*Submitted by:*

**Onondaga County Department of Water Environment Protection**  
650 Hiawatha Boulevard, West  
Syracuse, NY 13204-1194  
**MIGUEL E. EUCEDA**

## PROJECT PARTICIPANTS

NYSERDA Project Manager	Kathleen O'Connor, P.E. 17 Columbia Circle Albany, NY 12203-6399 (518) 8762-1090 x3422 Email: <a href="mailto:kmo@nyserda.org">kmo@nyserda.org</a>
ADG-to-Electricity Site Contact	Miguel E. Euceda OC Department of Water Environment Protection 650 Hiawatha Boulevard, West Syracuse, NY 13204-1194 (315) 435-3180 x418 Email: <a href="mailto:migueleuceda@ongov.net">migueleuceda@ongov.net</a>
CHP System Vendor/Designer	Milton CAT, Power Systems Division Contact: Chris Laverty Southworth-Milton, Inc. 101 Quarry Drive Milford, MA 01757 (508) 482-1639 Email: <a href="mailto:chris_laverty@miltoncat.com">chris_laverty@miltoncat.com</a>
Project Engineer	Environmental Engineer Associates, LLC Contact: Thomas Devine 6723 Towpath Road, Box 66 Syracuse, NY 13214 (315) 446-9120 x256 Email: <a href="mailto:twdevine@stearnswheler.com">twdevine@stearnswheler.com</a>
NYSERDA Technical Consultant	Malcolm Pirnie, Inc. Silvia Marpicati, P.E. 855 Route 146, Suite 210 Clifton Park, NY 12065 (518) 250-7328 Email: <a href="mailto:smarpicati@pirnie.com">smarpicati@pirnie.com</a>
NYSERDA CHP Website Contractor	CDH Energy Corp. Contact: Hugh Henderson, P.E. PO Box 641 Cazenovia, NY 13035 (315) 655-1063 Email: <a href="mailto:hugh@cdhenergy.com">hugh@cdhenergy.com</a>

## INTRODUCTION

This plan describes our approach to monitor the performance of the anaerobic digester gas (ADG) – to – electricity system that has been installed on the campus of the Syracuse Metropolitan Wastewater Treatment Plant (Metro). Biogas will be used to drive an engine-generator to produce power that will be consumed on-site. A monitoring system, already installed as part of the combined heat and power (CHP) enclosure will be utilized to measure and collect data necessary to quantify the electric power produced by the system. The data will serve as the basis for payment of three (3) years of performance incentive payments, which the Onondaga County Department of Water Environment Protection (OCDWEP) has applied for under a Standard Performance Contract (SPC) with New York State Energy Research and Development Authority (NYSERDA), based on a total contracted capacity of 350 kW.

## ADG SYSTEM DESCRIPTION

Onondaga County’s Anaerobic-to-Digester Gas (ADG) System, is comprised of three primary anaerobic digesters and one secondary anaerobic digester. Here, as part of an integrated waste management system, the mesophilic anaerobic digestion produces methane gas and carbon dioxide as a byproduct. This methane gas (biogas) is collected and stored in the secondary digester. Gas blowers compress this gas to 5 psig for consumption by up to five campus boilers, which produce low pressure steam to heat office spaces, buildings and the digesters themselves. The excess biogas, normally displaced on summer months, is burned (flared off) through one of three waste gas burners.

Metro’s combined heat and power system will utilize this biogas to produce valuable electricity throughout the year<sup>1</sup>. A 4 inch gas line has been installed to provide

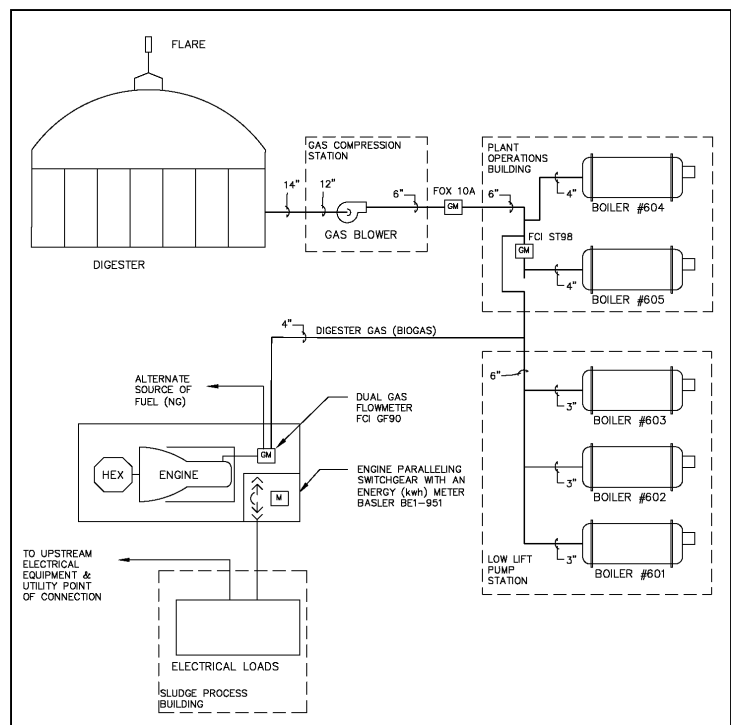

**Figure 1. Biogas Schematic**

<sup>1</sup> Continuous operation of the engine on biogas and supplementing other campus thermal loads with natural gas is most effective for Metro, as the value of the generated output outweighs the cost of purchased natural gas. - M. Euceda, "Cogeneration Analysis", February 28, 2008.

biogas fuel to the engine. The fuel line runs from the gas blowers into a newly installed filter, at the Digester Control House basement, to the CHP enclosure. Similarly, a 4 inch natural gas line has also been installed. However, this gas will not be used.

Furthermore, not only will the CHP produce the valuable electric commodity, but will also contain engine and exhaust heat recovery systems to supplement digester heating. An ultra low emissions engine, designed to meet stringent requirements of the US Environmental Protection Agency, is also part of this skid. A schematic diagram of Metro’s biogas system is shown in Fig.1.

**Table 1. Cogeneration System**

Digester	Anaerobic Digesters Mixed Flow, Covered, Heated
Feedstock	Thickened Sludge
Engine-Generator	Caterpillar 3508 350 kW output on biogas 480 VAC, 3 phase
Biogas Conditioning	Burgess & Manning
Engine Backup Fuel	Natural Gas
Heat Recovery Use	Digester Heating
Exhaust Heat Recovery	Cain Industries 659 BTU/hr
Engine Heat Recovery	Polaris PHE 1.662 MBTU/hr

The CHP sits on the Metropolitan Syracuse Wastewater Treatment Plant campus, adjacent to the Digester Control House and is housed in a weatherproof enclosure and contains the engine, jacket water & exhaust heat recovery systems, paralleling switchgear and electrical controls.

The generator is a Caterpillar 380 kW<sup>2</sup> unit with Caterpillar G3508 gas engine. The generator is a 480V synchronous generator that will only operate when utility power is available. The generator will “backfeed” 400 to 600 amps into a normal 3-phase breaker in Motor Control Center No. 3A (MCC) in the Sludge Process Building (SPB). The generated power will be consumed by the 300 to 400 kW loads in the panel, or it can be back fed through the 1000 kVA transformer at the SPB to serve other 4160-volt loads in the plant. See Fig. 2 for a partial electrical schematic of the Metro Plant.

<sup>2</sup> Generator is de-rated to 350kW when biogas fuel is used.

The CHP's electrical system includes paralleling switchgear to automatically synchronize the generator to the utility grid as well as to provide protective relays and controls to automatically isolate the CHP from the utility in the event of a power outage.

With the addition of the engine and exhaust heat recovery systems, the cogeneration unit will allow for 100 to 150 gpm of 180°F engine jacket water to be injected into the digester hot water heating loop, transferring approximately a total of 2.0 MMBtu/h of heat. It's anticipated this heat will meet the thermal loads of two digesters.

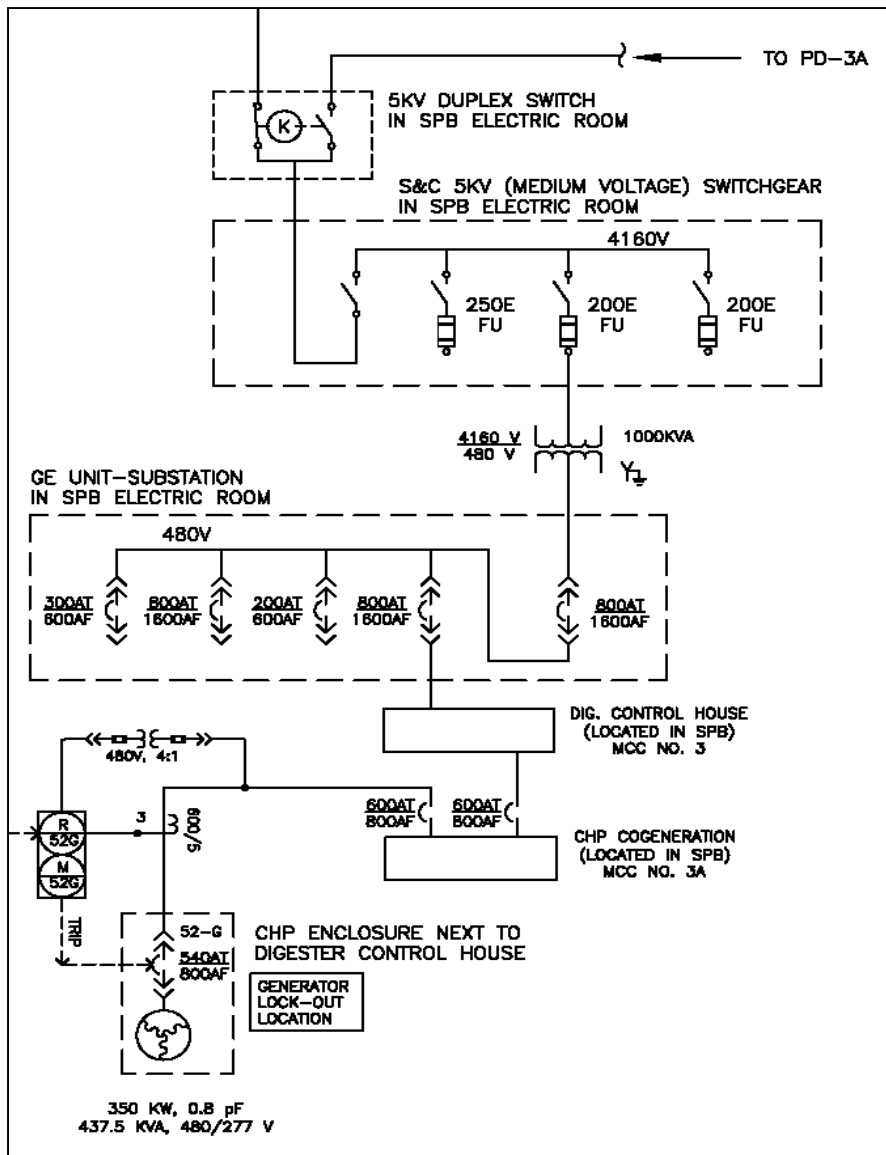

Figure 2. Electrical One-line Schematic

The pictures below show the CHP enclosure installed outside the Digester Control House, the two (2) hot water circulating pumps in the basement of the DCH, the engine generator skid, and the paralleling switchgear, within the CHP enclosure in the Sludge Process Building, which distributes the energy produced.



*Foreground: CHP Enclosure & Radiator Inter-cooler. Background: Digester Control House & Waste Burners (Flares)*



*Hot Water Heat Pumps in the Digester Control House Basement*



*Caterpillar 380 kW Engine/Generator Skid*

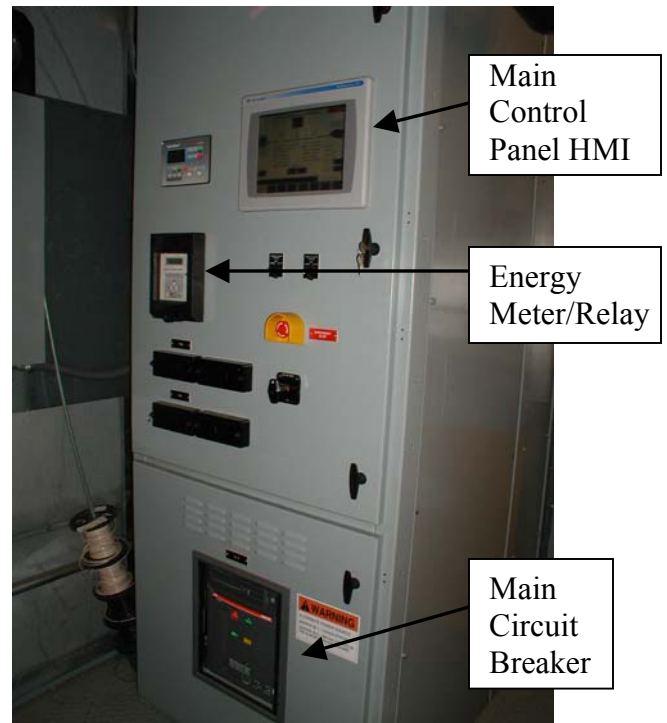

*Electrical Paralleling Switchgear, with Main Circuit Breaker, Protective Relay, and Controls*

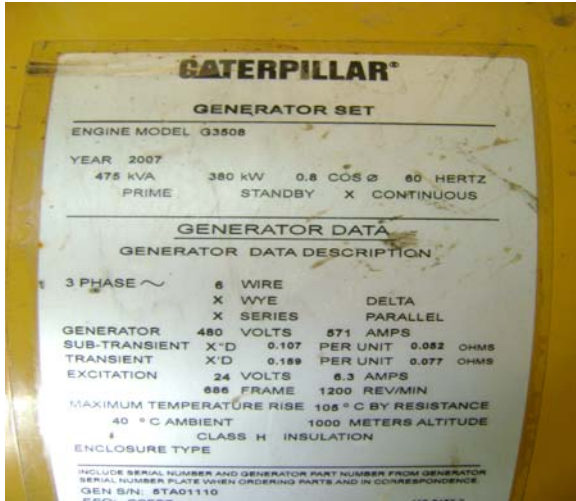

Generator Nameplate

Figure 3. System Components

## MONITORING SYSTEM EQUIPMENT

Figure 1 also shows the location of the electrical and gas meters that will be used, throughout the duration of the contract, to monitor system performance, electrical generation and gas consumption. Information on these data monitoring points is shown in Table 2.

Table 2. Monitor Points

Point Type	Point Name	Description	Instrument	Accuracy	Expected Range
Real	M	Engine-Generator Power	Basler Model BE1-951 Meter Function w/ (3) CTs, 600A	±1% at unity PF	0-440 kW  0-110 kWh/int
Real	GM	Engine Biogas Flow <sup>3</sup>	FCI Model GF90 Standard Conditions 70°C, 14.7 psi	±1% reading + 0.5% full scale	0-2600 ft <sup>3</sup> /int
Real	GM	Engine Natural Gas Flow <sup>3</sup>	FCI Model GF90 Standard Conditions 70°C, 14.7 psi	±1% reading + 0.5% full scale	0-2600 ft <sup>3</sup> /int

<sup>3</sup> Single flow meter is calibrated to measure both biogas and natural gas. Which gas is in use will be determined by status of solenoid valves on each gas line (open / closed). Solenoid valve status for both lines will be included in the recorded data.

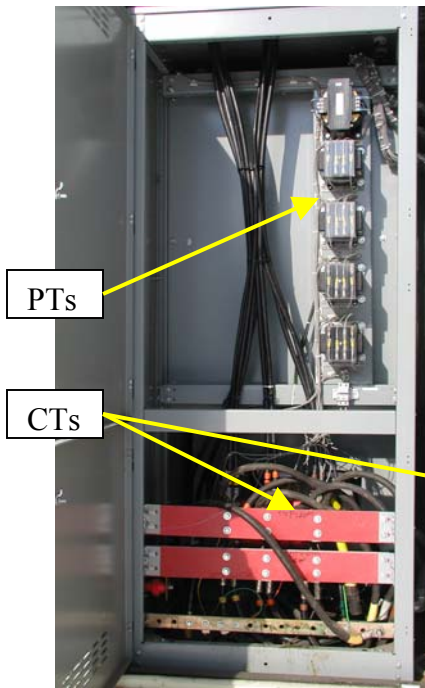

The electrical output of the new engine will be measured with an electronic wattmeter<sup>4</sup> (**M**), utilizing the CT's (current transformer) and PT's (potential transformer) provided in the rear of the switchgear (see Figure 4) and integral to the protective relay configuration of the system. This real time meter provides Watt, Watt-hour, VAR, VAR-hour, voltage and amp measurements. Display of the measured data, can be accessed by the Basler BE1-951 protective relay's Human Machine Interface (HMI), or the main control panel HMI, mounted on



the front door of the paralleling switchgear.

*Left: PT & CT Cubicle*

*Right: CT Close-up*

**Figure 4. Electrical Meter**

The gas input to the engine will be measured by FCI's GF90 direct mass gas flow meter (**GM**), which provides an output as a function of the velocity, standard volume and mass flow. The flow meter is composed of a remote thermal dispersion-sensing device (flow element) interconnected to a microprocessor based electronics control and display package (flow transmitter), as shown in Figure 5. The flow meter has been calibrated to measure mass flow of both gases. The flow element is installed on 4" horizontal flow tube, with flow straighteners, that feeds the engine. The flow transmitter measures and provides the Differential Resistance ( $\Delta R$ ) measurement of the flow element's input signal and provides the output signal.

<sup>4</sup> Electronic meter is based on pulse-output principle.

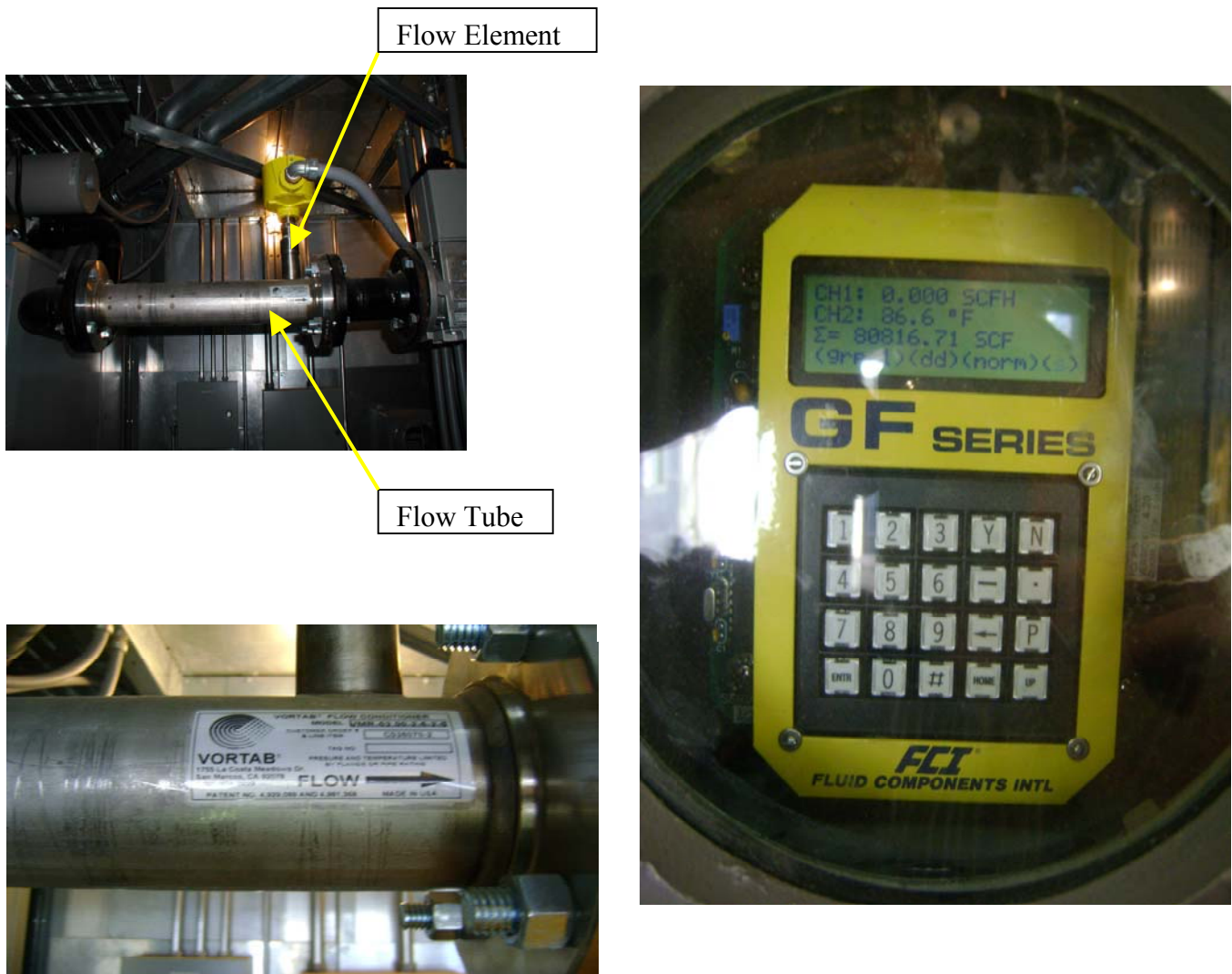

**Figure 5. Gas Flow Meter, Flow Meter Nameplate, and Display**

Both these instruments were provided and installed by the CHP contractor and are part of the CHP system. Measured variables are displayed locally and remotely in the main control panel HMI. Furthermore, these values are also made available to Metro’s Supervisory Control And Data Acquisition (SCADA) system, where the points can be trended, logged and later retrieved. Through the SCADA system WEP will log these points at 15 minute intervals and will average or totalize as appropriate. The

SCADA server is located in Metro's main Plant Operation Center and is connected to an uninterruptible power supply (UPS) to ensure data conservation. Data can be retrieved from the servers and exported. WEP will write the previous three days worth of data to either a .csv or .txt file and transfer it to CDH's secure FTP site daily.

The lower heating value (LHV) for the biogas is estimated to be 594 Btu/ft<sup>3</sup>, based on past measurements of the CO<sub>2</sub> content of the biogas. This value will be confirmed or adjusted based on average monthly measurements of carbon dioxide. A WEP designated operator will perform the CO<sub>2</sub> tests utilizing a Bacharach Fyrite<sup>®</sup> gas analyzer and report test results. Operations staff will analyze gas on a daily basis and record the results. A monthly average will be used to calculate the LHV of the biogas and populate the project log.

The backup fuel will also be monitored through the FCI GF90, as this flow meter has the ability (and has been calibrated) to accurately measure and display both gases. However, it is anticipated that this flow will remain at zero since this system will not be typically operated on natural gas<sup>5</sup>.

### **Management of Monitoring System**

Onondaga Metro will perform the following quality assurance and quality control measures to ensure the data produced from the monitoring system accurately describes system performance.

On a daily basis WEP's Instrumentation/Electrical Engineer, or his representative, will perform inspections of the digester and engine-generator equipment and record findings into the project log.

On a weekly basis WEP's Instrumentation/Electrical Engineer, or his representative, will perform inspections of the M&V meter installations and complete the routine maintenance on the meters, noting any abnormalities or unexpected readings. WEP will also maintain a weekly log of the cumulative power generation (kWh), natural gas flow (cf or ft<sup>3</sup>), and biogas flow (cf or ft<sup>3</sup>) from the engine in the event that data transfer to the NYSERDA CHP Website fails or other anomalies occur.

---

<sup>5</sup> Under National Grid's PSC No. 207, Leaf 102-B, "Environmentally Advantageous Technologies", January 1, 2008, systems under 400 kW that utilize biogas from anaerobic digestion may qualify for an exclusion if the renewable fuel accounts for more than 80 percent of engine fuel consumption. Otherwise, customers shall pay for the energy at commodity prices plus a "as-used" demand charge plus a "contract demand" charge.

On a weekly basis, WEP staff will review the data available on the NYSERDA CHP Website ([chp.nyserda.org](http://chp.nyserda.org)) to ensure it is consistent with their observed performance of the ADG system and logged readings. WEP will review the data using the reporting features at the web site, including:

- Monitored Data – Plots and Graphs
- RPS: Customer-Sited Tier Anaerobic Digester Gas-to-Electricity Program NYSERDA Incentive Program Reports

In addition, WEP will also setup and use the email reports that are available to help them track system performance, including:

- A periodic email report summarizing system performance and the estimated incentive,
- An email report sent out if data are not received at web site or do not pass the quality checks

The CHP website will automatically and evaluate the quality of the data for each interval using range and relational checks. The expected ranges for the sensors (see Table 2) will be used for the range checks. The relational check will compare the kWh production data and engine biogas flow for each interval to ensure both meters always provide non-zero readings at the same time (e.g., to detect if a meter has failed). Only data that pass the range and relational quality checks are used in the incentive reports listed above. However it is expected that all hourly data will be available from the NYSERDA CHP Website using the “Download (CSV file)” reporting option.

In the event of a communications or meter failure, WEP will work with CDH to resolve the issue in a timely manner.

If unanticipated loss of data occurs when the engine-generator continues to produce electricity, the facility will follow the procedures outlined in Exhibit D section III (from the applicants contract), i.e. using data from similar periods – either just before or after the outage – to replace the lost data. WEP understands that they can use this approach for up to two 36-hour periods within each 12-month performance reporting period. If more than two such data outages occur, WEP will provide information from other acceptable data sources (e.g., weekly recorded logs) to definitively determine the amount of power that was produced from biogas during the period in question.

## Annual M&V Reports

The Annual M&V Report will include a table (example provided below) showing the monthly kWh production and engine biogas consumption. The table will also include monthly values for biogas and natural gas consumed by the CHP, Biogas LHV & energy content, and adjusted kWh production. WEP may use data summarized in the Renewable Portfolio Standard: Customer-Sited Tier Anaerobic Digester Gas-to-Electricity Program NYSEDA Incentive Program Reports to populate this table; however, if WEP disagree with the Reports we will provide our own summary of the data along with a narrative justifying why we feel our calculations are more appropriate.

**Table 3. Summary Data for Annual M&V Report**

	Electricity Production (kWh <sub>gen</sub> )	Biogas Consumption (ft <sup>3</sup> )	Natural Gas Consumption (ft <sup>3</sup> )	Biogas LHV (ft <sup>3</sup> )	Natural Gas Energy Content Q <sub>NG</sub> (BTU)	Biogas Energy Content Q <sub>bio</sub> (BTU)	Adjusted Electricity Production (kWh <sub>adj</sub> )
Month 1							
Month 2							
Month 3							
Month 12							

Monthly values for lower heating value of the biogas, total energy content of the biogas, energy content of natural gas, and adjusted kWh production will be calculated as follows.

### Monthly Biogas Lower Heating Value

We will use the readings of CO<sub>2</sub> concentration in the biogas gathered weekly to estimate the average monthly Biogas Lower Heating Value using the following equation:

$$LHV_{biogas} = LHV_{methane} \cdot (1 - F_{CO_2})$$

where,

LHV<sub>methane</sub>: lower heating value of methane (911 Btu/ft<sup>3</sup> at standard conditions, 60 °F and 1 atm)  
 F<sub>CO<sub>2</sub></sub>: fraction of biogas that is CO<sub>2</sub> (average of readings for each month)

### Monthly Biogas Energy Content

We will calculate the average monthly Biogas Energy Content using the following equation:

$$Q_{biogas} = CF \cdot LHV_{biogas}$$

where,

CF: volume (ft<sup>3</sup>) of biogas in month

### Monthly Natural Gas Energy Content

Calculate the average monthly Natural Gas Energy Content using the following equation:

$$Q_{NG} = \#CF \cdot \left[ 1,028 \frac{Btu}{CF} \right]$$

where:

# CF – natural gas consumption in the period (standard cubic feet)

### Monthly Adjusted Electricity Production

Calculate the monthly adjusted electricity production using the following equation:

$$kWh_{adjusted} = kWh_{generator} \left[ \frac{Q_{biogas}}{Q_{biogas} + Q_{NG}} \right]$$

where:

kWh<sub>generator</sub> - actual electricity production

## APPENDICES

### Equipment Specification Sheets & Manuals

*Basler Multifunction Meter Model BE1-951:*

<http://www.basler.com/> (Website)

<http://www.basler.com/downloads/BE1-951GuideformSpec.pdf> (Product Brochure)

<http://www.basler.com/downloads/9328900990L.pdf> (Manual)

*Fluid Components International Thermal Gas Meter Model GF90:*

<http://www.fluidcomponents.com/> (Website)

[http://www.fluidcomponents.com/Sales%20Brochures/Flowmeters/GF\\_Brochure\\_RevH\\_VeriCal\\_RevB.pdf](http://www.fluidcomponents.com/Sales%20Brochures/Flowmeters/GF_Brochure_RevH_VeriCal_RevB.pdf) (Product Brochure)

[http://www.fluidcomponents.com/Industrial/Library/manuals/Flowmeters/GF90,%20GF92%20Guides%20&%20Manuals/GF%20Series%20Manual%20\(06EN003229f\).pdf](http://www.fluidcomponents.com/Industrial/Library/manuals/Flowmeters/GF90,%20GF92%20Guides%20&%20Manuals/GF%20Series%20Manual%20(06EN003229f).pdf) (Manual)