

**MEASUREMENT AND VERIFICATION (M&V)  
PLAN  
FOR  
PATTERSON FARMS DIGESTER GAS (ADG) SYSTEM**

January 12<sup>th</sup>, 2010

*Submitted to:*

**New York State Energy Research and Development Authority**  
17 Columbia Circle  
Albany, NY 12203-6399

**Patterson Farms, Inc.**  
1131 Townline Rd.  
Auburn, NY 13021

*Submitted by:*

**CDH Energy Corp.**  
PO Box 641  
2695 Bingley Rd.  
Cazenovia, NY 13035

## PROJECT PARTICIPANTS

NYSERDA Project Manager	Kathleen O'Connor x3422 <a href="mailto:kmo@nyserda.org">kmo@nyserda.org</a>
ADG-to-Electricity Program Contractor (the: "ADG Contractor")	Patterson Farms, Inc. 1131 Aurelius/Springport Townline Road Auburn, NY 13021
ADG Contractor Site Contact	Connie Patterson Jon Patterson Patterson Farms, Inc. 1131 Aurelius/Springport Townline Road Auburn, NY 13021 315-253-5966 315-729-0438 (Jon's mobile) <a href="mailto:connie7641@aol.com">connie7641@aol.com</a> <a href="mailto:jon.patterson@wwpfi.com">jon.patterson@wwpfi.com</a>
Digester System Vendor/Designer	Eric Fast RCM Digesters, Inc. P.O. Box 4716 Berkeley, CA, 94704 510-658-4466 510-658-2729 FAX <a href="mailto:efast@rcmdigesters.com">efast@rcmdigesters.com</a>
NYSERDA Technical Consultant (TC)	Hugh Henderson CDH Energy Corp. PO Box 641 Cazenovia, NY 13035 315-655-1063 <a href="mailto:hugh@cdhenergy.com">hugh@cdhenergy.com</a>
NYSERDA CHP Website Contractor (CHP Website Contractor)	Hugh Henderson CDH Energy Corp. PO Box 641 Cazenovia, NY 13035 315-655-1063 <a href="mailto:hugh@cdhenergy.com">hugh@cdhenergy.com</a>

## Introduction

This plan describes the approach to monitor the performance of the anaerobic digester gas (ADG) system that will be installed at Patterson Farms to produce biogas and electricity. Biogas will be used to drive an engine-generator to produce power that will be consumed on site and/or exported back to the local utility. A monitoring system will be installed to measure and collect the data necessary to quantify the electric power produced by the engine-generator. The data will serve as the basis for payment of three (3) years of performance incentive payments, which the farm has applied for under a Standard Performance Contract with NYSERDA. The farm has two engines that under two different Performance Contracts:

- The existing 180 kW engine that will receive maintenance payments per kWh
- The new engine (with a Total Contracted Capacity of 200 kW) will receive a capacity incentive payment and performance payments per kWh.

## ADG System Description

The digester system at the farm was designed by RCM Digesters, Inc. With the addition of the new Guascor engine-generator, the farm will have 400 kW electrical generation capacity. The two synchronous engine-generator systems with piping and controls that are installed in a pole barn near the digester. All the electrical loads at the farm have been consolidated into one 3-phase electrical service in order to accommodate the generator systems. The electrical system includes controls to synch the generator to the grid as well as protective relays and controls to automatically isolate the farm from the utility grid in the event of a utility power outage. In the event of an outage, the existing engine goes down, but the new engine remains up to provide backup power for the farm.

**Table 1. Biogas System**

Digester	RCM Digester Mixed Flow, Soft Cover, heated	
Feedstock	Dairy Manure, 1800 mature cow equivalents and Food Processing Waste, 360 mature cow equivalents	
Engine-Generator	<u>Existing</u> Cat G379 Approx 350 BHP Nameplate: 180 kW	<u>New</u> Guascor SFGLD 180 Nominal 338 BHP Nameplate: 225 kW
Biogas Conditioning	H <sub>2</sub> S Scrubber - RCM Digester De-watering system - Martin Machinery	
Engine Backup/startup Fuel	Propane	
Heat Recovery Use	Digester heating	
Additional Heat Recovery	None	



Original (existing) engine - Cat G379



New engine - Guascor SFGLD 180



H<sub>2</sub>S Scrubbers

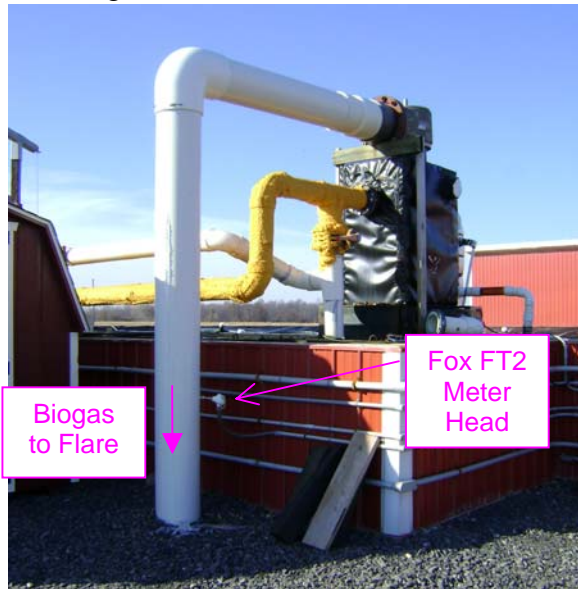

Relief Valve to "Passive" Biogas Flare



Engine Radiators Next to Pole Barn



Collection Pit

**Figure 1. Photos of System Components**



Roots Gas Meter – Existing ENGINE (FGE1)  
(now removed)



Fox FT2 Flow Meter – “Passive” Flare (FGF)



GenCon II Panel w/ Power Meter – NEW  
ENGINE (WG2)

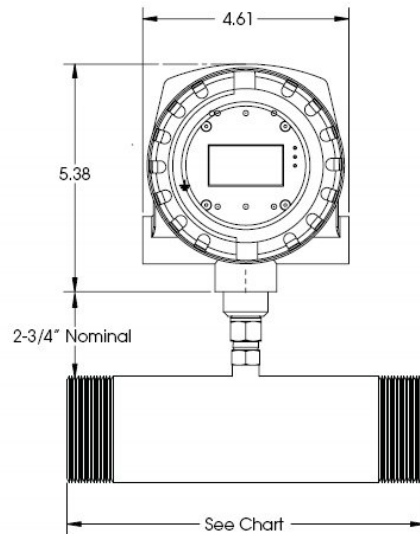

Sage SIP Flow Meter (FGE2) and (FGF2)

**Figure 2. Photos of Meters and Electrical Panels**

Figure 3 schematically shows the biogas system and engines. Biogas from the digester is either used in the engines or flared. The biogas flare operates using a mechanically-actuated valve that vents biogas to maintain the digester at the desired static pressure (e.g., 1-2 inches of water). Biogas for the engines is treated by Hydrogen Sulfide ( $H_2S$ ) scrubber and the de-watering system on the biogas skid. Three biogas blowers pressurize the gas to approximately 7 inches so it can be used in the engines (or sent to a high pressure flare).

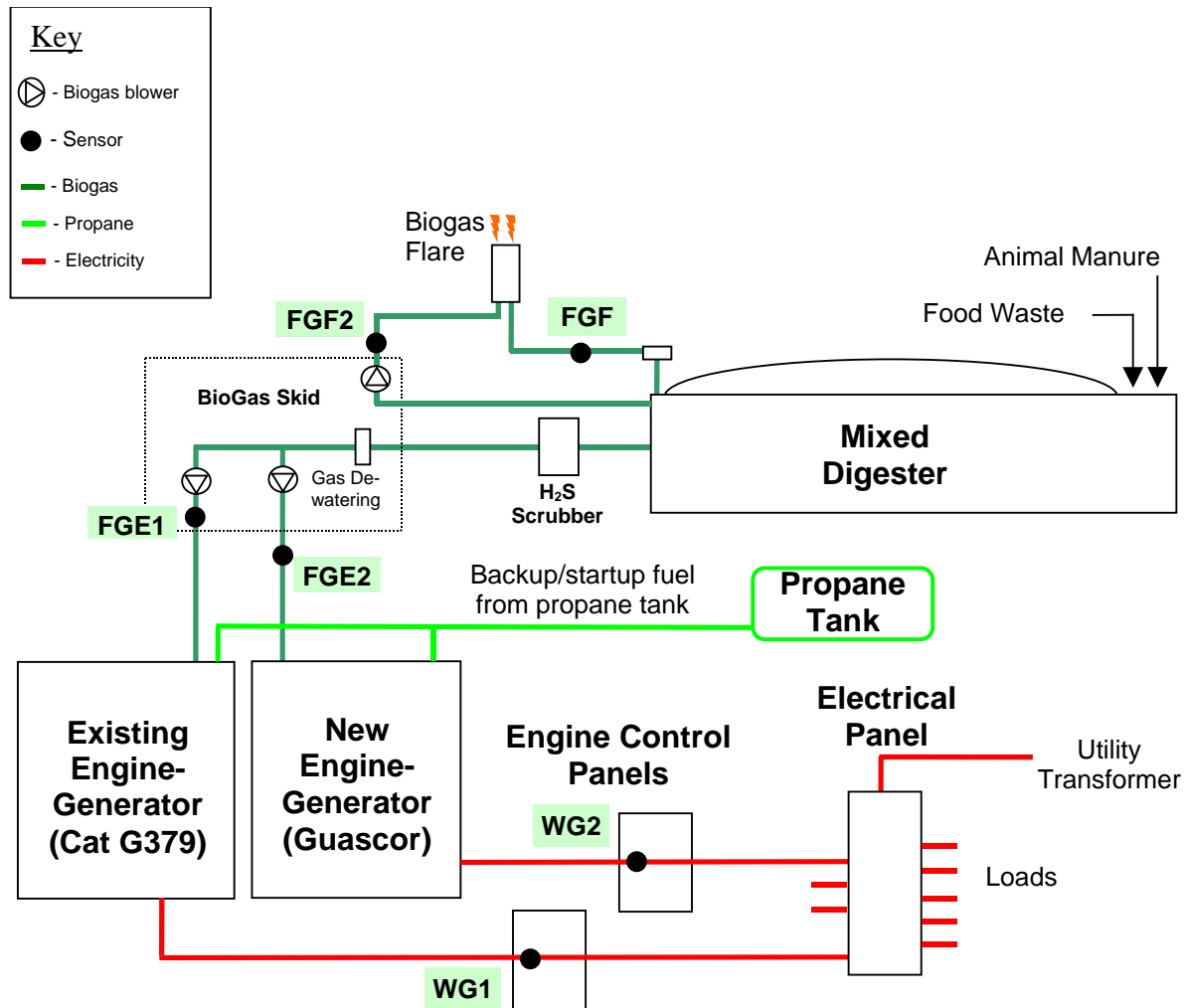

Figure 3. Schematic of Biogas System with Meters and Sensors Shown

## Monitoring System Equipment, Installation, Operation, and Maintenance

Figure 3 also schematically shows the locations of the monitoring points that will be used to measure system performance. Two gas meters will measure fuel gas input to the existing engine generator (FGE1) and to the new engine generator (FGE2). Separate electric meters will be installed to measure the kilowatts generated by the existing engine (WG1) and the new engine (WG2). The farm also has installed additional flow meters to measure the biogas flow to the passive flare (FGF) and the pressurized flare (FGF2). The specifications for these meters are shown in Table 2.

**Table 2. Monitored Points for ADG System**

Point Type	Point Name	Description	Instrument	Engineering Units	Expected Range
Pulse	WG1	Engine-Generator Power: EXISTING ENGINE	Wattnode Model WNB-3Y-480-P w/ (3) CTs, 400 amp 10.2 Wh/pulse Dual Pulse Output (DPO) option with LCD display	KWh	0-210
Pulse	WG2	Engine-Generator Power: NEW ENGINE	Gen-Tec Power Meter (Wh/pulse to be determined)	KWh	0-250
Pulse	FGE1	Engine Biogas Flow: EXISTING ENGINE	Sage inline flow meter <sup>1</sup> SIP-300 (0-450 cfm)	SCF	0 – 5000
Pulse	FGE2	Engine Biogas Flow: NEW ENGINE	Sage inline flow meter SIP-300 (0-450 cfm)	SCF	0 – 6000
Pulse	FGF2	Pressurized Biogas Flare Flow	Sage inline flow meter <sup>1</sup> SIP-300 (0-450 cfm)	SCF	0-2000
Pulse	FGF	“Passive” Biogas Flare Flow	Fox FT2 Flow Meter with Remote Display	SCF	0-2000

Notes:

- 1 – The pressurized biogas flare and existing engine now have a Roots 3M175 meter installed. This meter will be replaced by a new Sage Meter.

The electrical output of the new engine will be measured with a pulse-output power transducer (WG1). This power transducer will be installed in the electrical panel for the existing engine by the farm (and/or Martin Machinery). The transducer will be installed according to requirements in the “Wattnode Advanced Pulse Installation and Operation Manual” (<http://www.ccontrols.com/support/downloads.html>). The meter will have its own circuit breaker or inline fuse to provide over-current protection. The GenCon II Power meter installed as part of the protective relay system with the new engine (WG2) will be configured (by Martin Machinery) to provide a pulse output.

The biogas input to the existing engine (FGE1) was previously measured by a Roots gas meter. All the meters are being changed to a Sage SIP-300 hot-wire mass flow meter with pulse output proportional to the mass flow rate (Std ft<sup>3</sup>). Similarly the gas flow to new engine will be measured with a Sage SIP-300 (FGE1). The meters will be installed according to the Instruction provided by Sage. A log of maintenance activities for the meter will be maintained at the farm.

The lower heating value for the biogas is estimated to be 550 Btu/ft<sup>3</sup>, based on past measurements of the CO<sub>2</sub> content of the biogas. This value will be confirmed or adjusted based on weekly measurements of carbon dioxide using a Fyrite Gas Analyzer Model No. 10-5032 for CO<sub>2</sub> range 0-60%. Jon Patterson will direct the farm staff will perform the CO<sub>2</sub> tests and log the results on the biogas log sheet.

Both engines use propane as a backup/startup fuel flow. Propane use will not be continuously metered at this site. However, the farm will provide the propane delivery logs and summarize them in a spreadsheet table for the Annual M&V Report in order to account for periods when the backup/startup fuel is used. When both engines are installed, any propane use will be equally allocated between the two engines. The propane tank near the digester does not serve any equipment except the two engine-generators.

### **Data Logger Installation**

CDH Energy will install an Obvius AcquiLite (or AcquiSuite) datalogger to log the monitoring points listed in Table 2. The datalogger will be programmed to record the totalized data for each monitoring point at 15-minute intervals. A record of all multipliers and datalogger settings will be maintained. The datalogger will be located in the engine room next to the control panel, and will be connected to an uninterruptible power supply (UPS) to ensure the datalogger retains its settings and data in the event of a power outage. CDH Energy will provide a phone multiplexer/sharing module that will share the existing phone line with multiple devices. The phone line is now used by the Connected Energy (CE) monitoring system (and manually shared with the Martin Machinery system). CDH will use the sharing module to communicate with the Connected Energy System (\*1), the CDH datalogger (\*2), the Martin Machinery Genset I (\*3) and Martin Machinery Genset II (\*4). The NYSERDA CHP Website Contractor (CDH Energy) will call the datalogger nightly, via the phone modem link, to extract monitoring data from the logger and transfer it to the NYSERDA CHP Website. If communications are lost, the Obvius datalogger is capable of holding at least 15 days of 15-minute interval data.

### **Management of Monitoring System Data (Farm Responsibilities)**

The farm will perform the following quality assurance and quality control measures to ensure the data produced from the monitoring system accurately describes system performance.

On a daily basis, the farm equipment manager will perform inspections of the digester and engine-generator equipment and record findings into the project log.

On a weekly basis, the farm equipment manager will perform inspections of the M&V meter installations and complete the routine maintenance on the meters, noting any abnormalities or unexpected readings. The farm will also maintain a weekly log of the cumulative power generation (kWh) and gas flow (cf or ft<sup>3</sup>) from both the new and existing engines in the event that data transfer to the NYSERDA CHP Website fails or other anomalies occur.

On a weekly basis, the farm staff agrees to review the data available on the NYSERDA CHP Website ([chp.nyserda.org](http://chp.nyserda.org)) to ensure it is consistent with their observed performance of the ADG system and logged readings. The farm will review the data using the reporting features at the web site, including:

- Monitored Data – Plots and Graphs and
- RPS: Customer-Sited Tier Anaerobic Digester Gas-to-Electricity Program NYSERDA Incentive Program Reports

In addition, the farm staff will also setup and use the email reports that are available to help the track system performance, including:

- a periodic email report summarizing system performance and the estimated incentive,
- an email report sent out if data are not received at web site or do not pass the quality checks

The website will automatically take the data collected from the datalogger and evaluate the quality of the data for each interval using range and relational checks. The expected ranges for the sensors (see Table 2) will be used for the range checks. The relational check will compare the kWh production data and gas production data for each interval to ensure both meters always provide non-zero readings at the same time (e.g., to detect if a meter has failed). Only data that pass the range and relational quality checks are used in the incentive reports listed above. However, all hourly data are available from the NYSERDA CHP Website using the “Download (CSV file)” reporting option.

In the event of a communications or meter failure, the farm will work with CDH to resolve the issue in a few days.

If unanticipated loss of data occurs when the engine-generator continues to produce electricity, the farm will follow the procedures outlined in Exhibit D, i.e. using data from similar periods – either just before or after the outage – to replace the lost data. The farm understands that they can use this approach for up to two 36 hour periods within each 12-month performance reporting period. If more than two such data outages occur, the farm will provide information from other acceptable data sources (e.g., weekly recorded logs) to definitively determine the amount of power that was produced from biogas during the period in question.

### **Annual M&V Reports**

The Annual M&V Report will include a table showing the monthly kWh production, biogas production, and propane use. Separate tables will be provided for each engine. The farm may use the standardized incentive report (see above). Alternatively, they may provide their own summary of the data (using hourly CSV data downloaded from the Website) along with a narrative justifying why their data and calculations are more appropriate. The table will also include monthly values for the calculated lower heating value of the biogas, total energy content of the biogas, total energy content of the propane, and adjusted kWh production. The methods for calculating these values are provided below.



### Monthly Propane Energy Content

Calculate the average monthly Propane Energy Content using the following equation:

$$Q_{propane} = Gallons \cdot \left[ 83,500 \frac{Btu_{LHV}}{gal} \right]$$

where:

Gallons - propane consumption in the period (gallons)

### Monthly Adjusted Electricity Production

Calculate the monthly adjusted electricity production using the following equation:

$$kWh_{adjusted} = kWh_{generator} \left[ \frac{Q_{biogas}}{Q_{biogas} + Q_{propane}} \right]$$

where:

kWh<sub>generator</sub> - actual electricity production

### Reasonable Electrical Efficiency

The M&V Report will also provide a comparison of power output and fuel input for the engine to confirm their reasonableness. For instance the electrical efficiency – measured as power output (kWh<sub>generator</sub>) divided by the energy content of the fuel input (Q<sub>biogas</sub>+Q<sub>propane</sub>) in similar units and based on lower heating value – should be approximately 25% over any interval.

## Appendices

### Cut sheets and Manuals for:

#### **WattNode Meter Model WNB-3Y-480-P**

<http://www.ccontrols.com/downloads/WattNodeWNBpulseDataSheet.pdf>

<http://www.ccontrols.com/downloads/WNB-Pulse-Manual.pdf>

#### **AquiLite Data Acquisition Server – A7801-1**

<http://www.obvius.com/documentation/Obvius/A7801Cutsheet.pdf>

<http://www.obvius.com/documentation/Obvius/A7801Manual.pdf>

#### **Sage Meter Documentation**

[http://www.sagemetering.com/specs/inline\\_SRP\\_Model\\_prime.html](http://www.sagemetering.com/specs/inline_SRP_Model_prime.html)

#### **Fyrite Gas Analyzer**

[http://www.bacharach-inc.com/PDF/Brochures/fyrite\\_gas\\_analyzers.pdf](http://www.bacharach-inc.com/PDF/Brochures/fyrite_gas_analyzers.pdf)

<http://www.bacharach-inc.com/PDF/Instructions/11-9026.pdf>