

MEASUREMENT AND VERIFICATION (M&V) PLAN
FOR
TOWN OF LEWISTON WATER POLLUTION CONTROL CENTER
ANAEROBIC DIGESTER GAS (ADG) SYSTEM
Contract # 107N

August 7, 2009

Submitted to:

New York State Energy Research and Development Authority
17 Columbia Circle
Albany, NY 12203-6399

Submitted by:

Town of Lewiston Water Pollution Control Center
501 Pletcher Rd.
Lewiston, NY 14092-1099

Prepared by:

Wendel Duchscherer
140 John James Audubon Parkway
Suite 201
Amherst, NY 14228

Project No. 4338-02

PROJECT PARTICIPANTS

NYSERDA Project Manager	Kathleen O'Connor NYSERDA 17 Columbia Circle Albany, NY 12203-6399 (518) 862-1090 ext 3422 kmo@nyserda.org
Host Site / Applicant	Town of Lewiston Water Pollution Control Center Contact: Timothy R. Lockhart 501 Pletcher Rd. Lewiston, NY 14092-1099 (716) 754-8291 Lockhart13@msn.com Tlockhart@townoflewiston.us
Engineering Firm / Developer	CRA Infrastructure & Engineering, Inc. Contact: Christopher P. Martin P.E. 285 Delaware Avenue Buffalo, NY 14202 (716) 856-2142 cmartin@croworld.com
Equipment Vendors	Capstone Turbine Corporation 21211 Nordhoff Street Chatsworth, CA 91311 (818) 734-5300 Unison Solutions Incorporated Contact: Dave Broihahn 5451 Chavenelle Road Dubuque, IA 52002 (563) 585-0967 Emerson Climate Technologies Incorporated Contact: Charles Kuhlman Specialty Scroll Division (Sidney, OH) PO Box 905157 Charlotte, NC 28290-5157 (937) 498-3560

NYSERDA Technical Consultant
(TC)

Wendel Duchscherer A&E
Contact: Brian Sibiga P.E.
140 John James Audubon ParkWay
Suite 201
Amherst, NY 14228
(716) 688-0766
bsibiga@wd-ae.com

NYSERDA CHP Website Contractor
(CHP Website Contractor)

Hugh Henderson
CDH Energy Corp.
PO Box 641
Cazenovia, NY 13035
(315) 655-1063
hugh@cdhenergy.com

Introduction

The Town of Lewiston Water Pollution Control Center (WPCC) is a 2.75 million gallon per day conventional activated sludge wastewater treatment plant that services the Town of Lewiston, Town of Porter, Village of Lewiston and the Village of Youngstown.

The sludge that is generated by the treatment process is digested using two (2) anaerobic digesters. The primary digester is heated and mixed while the secondary digester is unheated and unmixed. The majority of the digestion occurs in the primary digester. The secondary digester is used to settle the thickened digested sludge from the primary digester while its floating cover acts as a gas holder for biogas storage. Biogas is produced as a byproduct of the digestion process and contains approximately 50-75% methane, the main component of natural gas. This biogas can be conditioned and utilized as a fuel source.

This plan describes the approach used to monitor and verify the performance of the anaerobic digester gas (ADG) system that is installed at the Town of Lewiston Water Pollution Control Center (WPCC) to produce biogas and electricity. Biogas is used to drive two (2) micro-turbine generators to produce power that is consumed on site and/or exported back to the local utility. A monitoring system is installed to measure and collect the data necessary to quantify the electric power produced by the micro-turbine generators. The data will serve as the basis of payment for a capacity incentive to help with capital expenses associated with the procurement of new generation equipment and three (3) years of performance incentive payments, which WPCC has applied for under a Standard Performance Contract with NYSERDA based on a Total Contracted Capacity of 30 kW.

ADG System Description

The digesters at WPCC have been in place since the plant began operation in 1978. The Town of Lewiston WPCC has been involved with cogeneration or combined heat and power (CHP) utilizing biogas as a fuel since 1985. The first project was the installation of a 51-kW, grid connected Cummins reciprocating engine and generator from a NYSERDA grant. This unit was replaced in 1997 with a 100-kW Caterpillar reciprocating engine. The 100-kW generator was replaced in 2001 when, through a grant from the New York Power Authority (NYPA), two (2) 30-kW Capstone micro-turbines and an air-to-liquid heat exchanger were installed at the WPCC. The micro-turbines operated as the primary CHP units until mid 2005 when, due to operator error, MT #1 failed. MT #1 remained out of service for two (2) years while the Town of Lewiston unsuccessfully negotiated with NYPA to receive a block of low-cost power for the WPCC.

During the two-year period that MT #1 was out of service, various parts were cannibalized from MT #1 to serve the still-operating MT #2 and fuel booster system, and piping modifications were made to the MT #2 feed pipes. Improvements included piping the discharge from the operating MT #2 fuel booster in series with the unused Van Air dryer of MT #1. This increased length of discharge piping allowed the ambient air to cool the biogas fuel in the piping prior to entering the Van Air desiccant dryers, allowing more condensate to be removed from the fuel and resulting in improved filter and fuel valve life over the original piping configuration.

As part of this project, two (2) new low-hour Unison 30kW engines (the second engine as backup) have replaced the broken engine in MT #1. The purchase of two (2) low-hour engines provided a cost savings of about \$6,000 over a single new replacement engine from Capstone. System operation upgrades that evolved on MT #2 while MT #1 was off line were applied to MT #1's operating train, including piping upgrades, addition of biogas conditioning equipment, and interconnection equipment. The Town of Lewiston has procured, installed and placed into service the necessary equipment to meet the requirements of this program. It is understood that the hours of service prior to measurement and verification activities cannot be claimed under the NYSEDA incentive program; however, the use of the rehabilitated micro-turbine has provided an electrical cost savings for the WPCC and offered an extended test period of the functionality of the system.

Heat recovery (QHR) is accomplished utilizing a fin/coil type air to liquid heat exchanger (HX). The exhaust gas from the micro-turbine passes through this heat exchanger creating hot water. This hot water is passed through a plate frame liquid to liquid heat exchanger and used to heat the digester process and the inhabited spaces of the digester control building. This recovery of heat energy from the turbine exhaust satisfies about 95% of the heat requirements of this building during the winter months (natural gas is utilized for backup space heating in the winter) and over 100% during the summer. Figure 2, in Appendix A, depicts the heat recovery system at the WPCC.

All the electrical loads at the WPCC (including lighting, HVAC, plugs loads, etc.) have been consolidated into a 3-phase electrical service in order to accommodate the generator system. The electrical system includes controls to synch the generator to the grid as well as a protective relay and controls to automatically isolate the WPCC from the utility grid in the event of a utility power outage. The WPCC energy consumption is roughly 1,160,000 kWh/year. Peak demand was 222 kW in 2008. Approximately 30 % of the electrical needs of the WPCC are met by the use of the micro-turbines.

Current energy use and demand at the Town of Lewiston Water Pollution Control Center is monitored in two locations on site. The local electrical utility, National Grid, meters at a single point for total kilowatt hours and peak demand. This meter location is located in the main switch gear that serves as the interface between the WPCC and National Grid. WPCC can also monitor electrical usage being delivered by the local utility at the main process control panel located in the administration building of the WPCC. The second metering point is located at the micro-turbine metering cabinet located in the micro-turbine building. This meter totalizes the output in kilowatt hours of the two (2) 30-kW micro-turbines. A third meter is dedicated to MT #1 to quantify how much of the energy generated is coming from MT #1. MT #1 output is the only electricity that can be counted as part of this ADG program. The 100kW generator utilized as a backup generator is grid-isolated, and operates on biogas. There is also a 230kW diesel standby generator onsite.

Table 1. Biogas Systems at the Lewiston WPCC

Digesters	Two (2), installed in 1978
Feedstock	Municipal Sewage, 2.75 MGD
Turbine-Generators	Capstone C-30, 480 VAC, 3 phase
Biogas Conditioning	Siloxane and H ₂ S removal, dewatering
Engine Backup/startup Fuel	None
Heat Recovery Use	Digester heating, space heating

Figure 1. Photos of System Components



MT #1, Air to Liquid Heat Exchanger, MT #2



Digester Boiler



MT #1 Gas Compressor



Biogas Conditioning Skid



Terminal Cabinet



Backup 100kW Generator

Biogas from the digesters is either used in the micro-turbine engines or flared. The digester pressures are maintained at 7.8 to 8.8 inches WC. Biogas is piped from the digesters, dewatered, and filtered in the biogas conditioning room and pressurized to 70 psi in the Copeland pressure boosters, one for each micro-turbine. Biogas cools and receives further desiccation as it travels a lengthy section of piping prior to entering the micro-turbines. Only the reconditioned MT #1 micro-turbine will receive incentives through the ADG-to-Electricity Program. Figure 3, in Appendix A, depicts the biogas fuel flow from the digesters to the micro-turbines.

Monitoring System Equipment, Installation, Operation, and Maintenance

Figure 3 also shows the location of the gas data monitoring point used to measure system performance. A gas meter measures fuel gas input to the engine generator (FGE). Information on this data point is shown in Table 2:

Table 2. Monitored Points for ADG System

Point Type	Point Name	Description	Instrument	Engineering Units	Expected Range
Pulse	WG	Engine-Generator Power (of new engine only)	E-Mon Model 480100ST KIT	kW kWh	0-30 kW 0-7.5 kWh/15 minutes
Pulse	FGE	Engine Biogas Flow (to new engine only)	Sage Metering Inc. Model SIG-05-15 for biogas (2-in)	ft ³	0-175 ft ³ /15 minutes

A Landis and Gyr meter, installed in 2001 and located in the Terminal and Metering Cabinet totalizes the output of both micro-turbines. The difference between these two meters equals the kWh output of MT #2. The electrical output from MT #1, as monitored by the E-Mon meter, is the only output eligible to be counted under the NYSERDA incentive program. Electrical metering for the incentive program is accomplished using a pulse output transducer (**WG**) with a direct-read, 8-digit LCD display. This meter, dedicated to MT #1 and manufactured by E-Mon of Lancaster PA was installed by WPCC staff according to instructions in the E-Mon D-Mon[®] Installation Manual (Website link in Appendix B). The meter will have its own circuit breakers and current sensors to provide over-current protection. Figure 4, in Appendix A, is a one line schematic of the electrical metering. Figure 4 also shows the location of the electrical data monitoring point; a power meter measures the kilowatts generated (**WG**) by the micro-turbine generator.

The biogas input to the engine will be measured by a Sage gas meter (**FGE**) that provides pulse output proportional to the volume flow that is compensated for temperature to 60° F. The Sage meter will be installed in the biogas pipe feeding the new MT #1 engine in accordance with the provisions of the “Sage Thermal Gas Mass Flow Meter Operations and Instruction Manual for Industrial Style Models SIP and SRP Document Number 100-0001 Revision 05-SIP/SRP (Sage Prime™)” (Website link in Appendix B). The pipe will have a parallel bypass line with appropriate valves allowing for continuing

use of the engine should the meter need to be removed for cleaning or repair. A log of maintenance activities for the meter will be maintained at the site.

The lower heating value for the biogas is estimated to be 630 Btu/ft³, based on past measurements of the CO₂ content of the biogas. This value will be verified weekly based on measurements of carbon dioxide using a Fyrite Gas Analyzer Model No. 10-5032 for CO₂ range 0-60%. WPCC personnel will perform the CO₂ tests and log the results in the project log.

CDH Energy will install an Obvius AcquiLite data logger to compile and log the data from the two monitoring points listed in Table 2 (see data logger details in Appendix B). The data logger will be programmed to average or totalize data for each monitoring point for each 15-minute interval as appropriate. A record of all multipliers and data logger settings will be maintained. The data logger will be located in the engine room next to the control panel, and will be connected to an uninterruptible power supply (UPS) to ensure the data logger retains its settings and data in the event of a power outage. The UPS is capable of powering the data logger for at least one day. WPCC will provide a dedicated phone line (or an Ethernet connection with fixed IP address) that will be used to communicate with the data logger. The NYSERDA CHP Website Contractor (CDH Energy Corp.) will communicate with the data logger nightly to extract monitored data from the data logger and transfer the data to the NYSERDA CHP Website. If communications are lost, the Obvius data logger is capable of holding at least 15 days of 15-minute interval data.

The Lewiston WPCC will be responsible for the cost to purchase and install the power meter (**WG**) and engine biogas meter (**FGE**).

Management of Monitoring System Data (WPCC Responsibilities)

Employee training will follow the manufacturers' recommendations per their instruction manuals. The WPCC staff is familiar with and has been involved for over 30 years with monitoring equipment so the training period is expected to be uneventful. The WPCC utilizes a computerized preventive maintenance system that tracks the required tasks and equipment maintenance history. The new monitoring equipment will be entered into the maintenance system and the manufacturer's required schedules followed.

Items of the monitoring system that become problematic will be replaced. It is understood by the WPCC that monitoring is a part of the monies being offered by the grant and the terms for valid data gathering will be honored.

WPCC personnel will perform the following quality assurance and quality control measures to ensure the data produced from the monitoring system accurately describes system performance.

Upon installation of the monitoring equipment, the WPCC Chief Operator will work with the installation contractors or equipment vendors to ensure that the monitoring equipment is functioning properly. The Chief Operator will review the operation manuals for an understanding on how to use and maintain these meters.

The Chief Operator will then setup a training session to relay these operation & maintenance procedures to all other appropriate employees.

On a daily basis, WPCC personnel will perform inspections of the digester and engine-generator equipment and record findings into the project log.

On a weekly basis, WPCC personnel will perform inspections of the M&V meter installations and complete the routine maintenance on the meters, noting any abnormalities or unexpected readings.

On an annual basis, the WPCC personnel will perform a review of the M&V meter installations and performance throughout the year and complete any required recalibration or maintenance as indicated in the operation and maintenance manuals. Should the meters require repair or replacement, WPCC personnel will contact the meter vendor for direction.

WPCC personnel will also maintain a weekly log of the cumulative power generation (kWh) and gas flow (cf. or ft³) from the new engine in the event that data transfer to the NYSERDA CHP Website fails or other anomalies occur.

On a weekly basis, WPCC staff will review the data stored on the NYSERDA CHP Website (chp.nyserdera.org) to ensure it is consistent with their observed performance of the ADG system and logged readings. If data abnormalities are identified, WPCC will take corrective action. WPCC personnel will review the data using the reporting features at the website, including:

- Monitored Data – Plots and Graphs
- RPS: Customer-Sited Tier Anaerobic Digester Gas-to-Electricity Program NYSERDA Incentive Program Reports

The website will automatically take the data collected from the data logger and evaluate the quality of the data for each interval using range and relational checks. The expected ranges for the sensors (see Table 2) will be used for the range checks. The relational check will compare the kWh production data and gas production data for each 15-minute interval to ensure both meters always provide non-zero readings at the same time (e.g., to detect if a meter has failed). Only data that pass the range and relational quality checks are used in the incentive reports listed above. However, all hourly data are available from the NYSERDA CHP Website using the “Download (CSV file)” reporting option.

To help track system performance, WPCC staff will sign up for automated emails at the NYSERDA CHP Website in order to receive:

- A periodic email report summarizing system performance and the estimated incentive
- An email report sent out if data is not received at web site or does not pass the quality checks

In the event of a communications or meter failure, WPCC personnel will work with CDH to resolve the issue in a few days.

The WPCC is continually staffed and equipment checks are manually made and logged on the various shifts. The manual readings and the automatic readings will be compared and any abnormalities

investigated. By gathering and comparing manual vs. automatic readings should minimize the potential for data gaps. If unanticipated loss of data occurs when the engine-generator continues to produce electricity, WPCC personnel will follow the procedures outlined in Exhibit D of their contract, i.e. using data from similar periods – either just before or after the outage – to replace the lost data. WPCC personnel understand that they can use this approach for up to two (2) 36-hour periods within each 12-month performance reporting period. If more than two such data outages occur, WPCC personnel will provide information from other acceptable data sources (e.g., weekly recorded logs) to definitively determine the amount of power that was produced from biogas during the period in question.

Annual M&V Reports

Measurement and verification (M&V) reports are designed to quantify the variation of the ADG system’s gas consumption, power output and efficiency over an extended period of time as well as demonstrate the benefits of heat recovery for other uses at the facility. As part of NYSERDA’s ADG program, the M&V Report must be completed annually for a period of three (3) years. WPCC personnel will prepare the Annual M&V Report, which will include a table showing the monthly kWh production, biogas sent to the engine, and other data listed in Table 3. WPCC personnel may use the NYSERDA Incentive Program Reports found on the CHP website. Alternatively, they may provide their own summary of the data (using hourly CSV data downloaded from the Website) along with a narrative justifying why their data and calculations are more appropriate. The methods for calculating these values are provided on the following page.

Table 3. Summary of Monthly Data for Annual M&V Report

First Date of the Month	Monthly Periods	Number of Days in Reporting Period	Electricity Production, kWh _{generator}	Biogas to MT#1, CF (cubic feet)	Biogas LHV, BTU (cubic feet)	Biogas Energy Content, Q _{biogas} (BTU)
TOTALS						

Data calculations will be accomplished using the existing metering for electrical and biogas generation as well as new metering that will be installed to isolate the fuel usage in cubic feet of biogas

consumption and electrical energy generated by MT #1. By testing for the lower heat value of the biogas the BTU consumption of the micro-turbines may also be calculated.

WPCC personnel will calculate monthly values for lower heating value of the biogas and total energy content of the biogas. The micro-turbines run only on biogas. There is no backup fuel or start-up fuel. Turbine outputs are turned down when biogas availability decreases. Therefore, no additional calculations are required to determine adjusted electricity production.

Calculations

Monthly Biogas Lower Heating Value

WPCC personnel will use the readings of CO₂ concentration in the biogas gathered weekly to estimate the average monthly Biogas Lower Heating Value using the following equation:

$$LHV_{biogas} = LHV_{methane} \cdot (1 - F_{CO_2})$$

where,

LHV_{methane}: lower heating value of methane (911 Btu/ft³ at standard conditions, 60 °F and 1 atm)
F_{CO₂}: fraction of biogas that is CO₂ (average of readings for each month)

Monthly Biogas Energy Content

WPCC personnel will calculate the average monthly Biogas Energy Content using the following equation:

$$Q_{biogas} = CF \cdot LHV_{biogas}$$

where,

CF: volume (ft³) of biogas in month

Figure 2. Heat Recovery

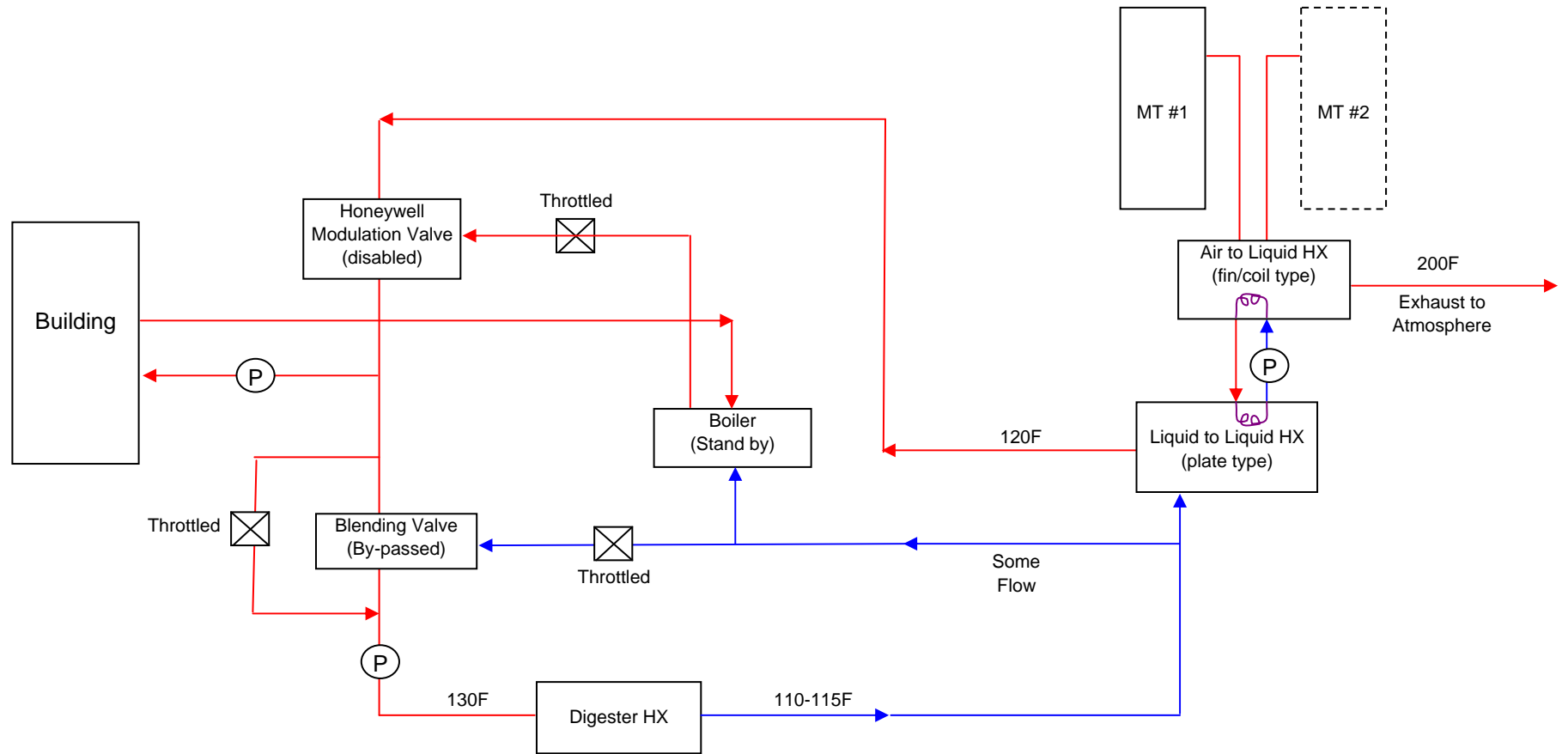

Figure 3. Biogas Fuel Flow

Low Pressure Biogas 8" WC

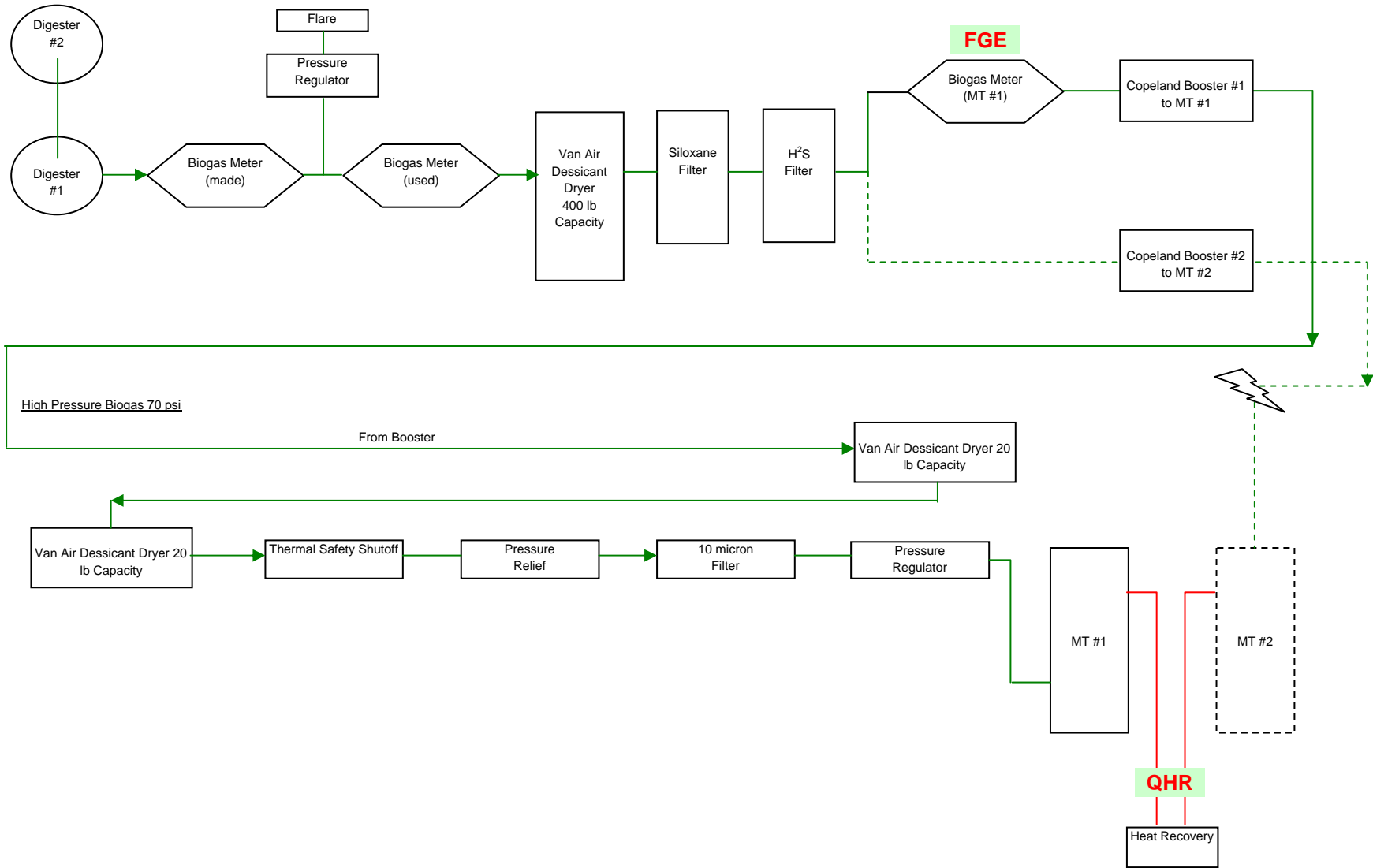

Figure 4. Electricity Metering

