

4C Foods Corporation

Engines for Process and HVAC Loads

DG/CHP Program

Project Profile

Combined heat and power for
Food Production Facility



Overview

4C Foods Corporation is a food processing company located in Brooklyn, NY. The facility operates five to six days per week up to 12 hours per day. The demand for heat and electricity follows the level of production, a characteristic favorable to CHP applications.

Two 150 kW and one 80 kW engine-generator set were installed at the facility. Electricity is supplied to two services though heat is recovered to a common loop serving a production load and the building HVAC. The system provides 80% of the site's annual electricity consumption at an apparent CHP efficiency of 84% HHV.

The Application

Thermal requirements at the site are dominated by a single process load and the demand for seasonal space heating. Air at 135°F is used for drying grated cheese. Prior to the installation of the CHP system a boiler was used to provide this heat as well as to supply steam to fan coils distributed throughout the plant. Limited areas of the facility were also being cooled using DX type air handling units.

Since most of the HVAC equipment was in need of replacement, 4C Foods decided to install absorption chillers and convert the fan coils to use hot water at a supply temperature compatible with an engine based CHP system. A new hot water coil was similarly installed to pre-heat the air flow to the cheese dryer and further offset the demand for steam.



Engine Modules Housed Inside Shipping Container

Quick Facts

Location:
Brooklyn, NY (Con Ed)

Installation Date:
June 2004

Operating Experience:
42 months (as of Dec 2007)

CHP Equipment:
Two Coast Intelligen
150-IC Engines
One Coast Intelligen
80-IC Engine

Generating Capacity:
380 kW

Heat Recovery Application:
Heated air for production and
building HVAC (1,930
MBtu/h peak)

Design CHP Efficiency:
>82% HHV

Type of Fuel:
Natural Gas

Annual Utility Savings:
\$200,000 per year (measured)

Simple Payback:
Under 6 years (estimated)

CHP System and Equipment

The CHP system at 4C Foods was configured on three natural gas fired engine-generator sets; two 150 kW and one 80 kW unit serving separate load centers. This proved more economical than combining the services. Installation costs were further reduced by pre-assembling the generators and electrical components in a container that was shipped to site where the remaining equipment was added. Waste heat from the engine jackets and exhaust is recovered in a common hot water loop and used to provide space conditioning and offset a single process load. Excess heat can be rejected to atmosphere through an external radiator. Automatic controls sequence the operation of each generator and modulate the electrical output to follow the site load. No power is exported to the grid.

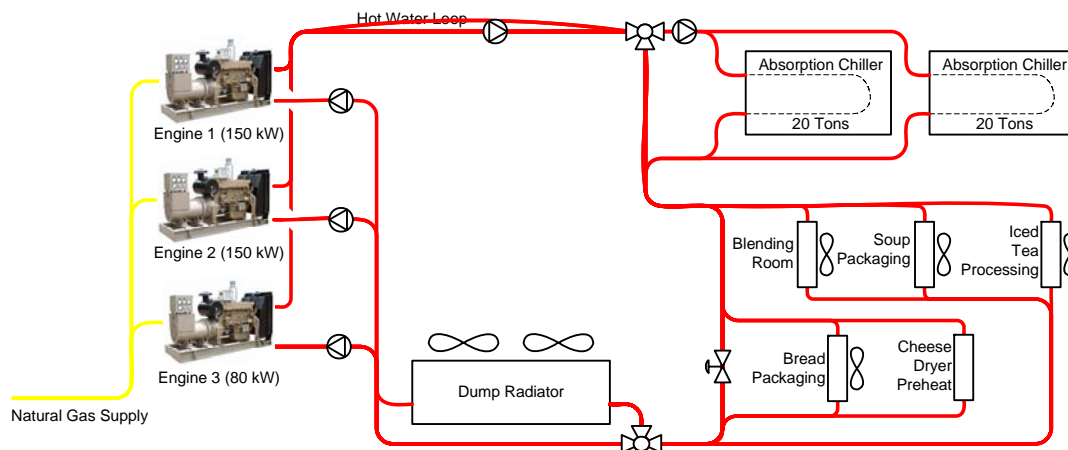

Economics and Environmental Benefits

Hourly data have been collected from the site since May 2005 and are available on NYSEDA's DG/CHP web site. Performance data from 2006 indicate the CHP system produced in excess of 1,000,000 kWh and reduced 4C Food's energy costs by 38%. Expenditures for utility supplied electricity were reduced by more than \$280,000 under the applicable Consolidated Edison rates. Overall savings approached \$17,000 per month. The high level of thermal utilization contributed significantly to the savings. Reports from the site indicate 96% of the thermal energy available from the CHP system was usefully recovered. The CHP system is expected to reduce net carbon dioxide emissions by 720 tons annual.



Field Assembled Mechanical Equipment



Pre-wired Control Panel

Summary of Benefits

- Uses nearly all of the recoverable heat to meet process and HVAC loads
- High CHP efficiency since plant output is modulated to follow electric loads
- Cost savings approach \$17,000 per month

“I liked the idea that you could reuse the the waste heat. And in addition to saving money, I liked the idea we’re doing something constructive.”

- Wayne Celauro,
Vice-President, 4C
Foods Corporation

Web Links and Further Information:

Energy Concepts –
Developer/Engineer

www.nrg-concepts.com

Engine
Manufacturer

www.coastintelligen.com

Other
DG/CHP
Resources

chp.nyserda.org

Prepared for NYSEDA by:
CDH Energy Corp.
Cazenovia, NY 13035
315-655-1063
www.cdhenery.com
dgchp_data@cdhenery.com