



New York State Energy Research and Development Authority

# Arrow Linen

## Engines for Hot Water Process Loads

DG/CHP Program

Project Profile

# Combined heat and power for Commercial Laundry



### Overview

Arrow Linen is an industrial laundry facility located near Prospect Park in Brooklyn, NY. The facility uses large quantities of hot water and electricity to clean uniforms, table linens and other items for restaurant and institutional customers.

Two 150 kW engines were installed to produce electric power and preheat hot water consumed in the facility. Because hot water use is high and entering water temperatures are low, the system achieves consistently high CHP efficiency (over 80% HHV). The engines operate about 10-14 hours per day, six days a week.

### The Application

Arrow Linen consumes large quantities of hot water and electricity in their laundry cleaning processes. Hot water use is about 100,000 gallons/day. Before the CHP system was installed, thermal loads were met with a 500 HP medium-pressure, steam boiler. Steam is primarily used in steam-to-hot water heat exchangers. To cut energy costs, the facility had previously installed heat exchangers to extract thermal energy from the process waste-water before discharging it to the sewer system. This waste-water heat exchanger system preheats entering city water to approximately 74°F.

Engines were a good fit in this application because large amounts of hot water must be heated to 160°F. Hot water and electricity loads in the facility are both coincident with the daily work shift (from 4 am to 6 pm, Monday through Saturday).

### Quick Facts

**Location:**  
Brooklyn, NY (Con Ed)

**Installation Date:**  
April 2003

**Operating Experience:**  
34 months (as of Feb. 2006)

**CHP Equipment:**  
Two Coast Intelligent  
150-IC Engines

**Generating Capacity:**  
300 kW

**Heat Recovery Application:**  
Process hot water and boiler  
makeup (2,000 MBtu/h peak)

**Design CHP Efficiency:**  
>80% HHV

**Type of Fuel:**  
Natural Gas

**Annual Utility Savings:**  
\$120,000 per year (measured)

**Simple Payback:**  
Under 3 years (estimated)



Rooftop-Mounted Engine Modules

## CHP System and Equipment

The combined heat and power system at Arrow Linen includes two natural-gas fired 150 kW Coast Intelligent engines. The engines run each weekday and are automatically controlled to match their electrical output to the building load (so no power is exported to the utility). A hot water loop recovers heat from the engine block as well as an exhaust-to-water heat exchanger. The recovered heat is provided meet domestic hot water loads as well as to preheat makeup water for the boiler feedwater system. A dump radiator rejects heat to ambient if these thermal loads cannot use all the available heat.

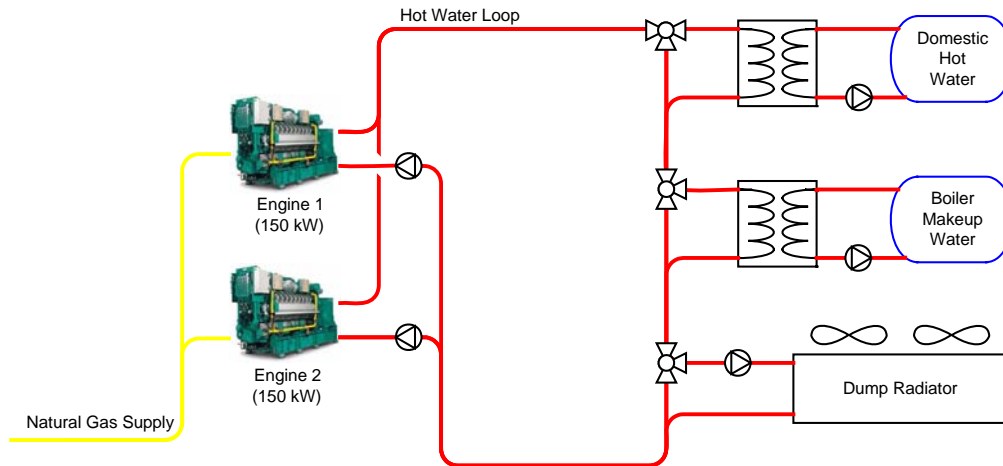

## Economics and Environmental Benefits

Monitored data are being collected from this site and displayed on the web by Connected Energy. The collected data includes generator power output, facility utility power import, engine gas consumption, and heat recovery temperatures and flows. Hourly data from this site have been automatically loaded into NYSERDA's DG/CHP data system since March 2005. The CHP system uses most of the available waste heat and has a total system efficiency over 80% on an HHV basis. Monthly utility cost savings are about \$10,000 per month under Consolidated Edison rates.



*Exhaust-to-Water Heat Exchanger*



*Engines & Auxiliary Equipment During Installation*

## Summary of Benefits

- Uses nearly all available heat recovery to meet process hot water loads
- High CHP efficiency since engine only operates when the process is active
- Cost savings of \$10,000 per month

“For someone like us, this savings has enabled us to stay in New York where our business is. Without the benefits, we were seriously considering moving to Long Island or New Jersey”

- Frank Park, Arrow Linen Spokesperson

## Web Links and Further Information:

Energy Concepts – Developer/Engineer

[www.nrg-concepts.com](http://www.nrg-concepts.com)

Engine Manufacturer

[www.coastintelligen.com](http://www.coastintelligen.com)

Other DG/CHP Resources  
[chp.nyserda.org](http://chp.nyserda.org)

[www.enerview.com/ny/ArrowLinen.asp](http://www.enerview.com/ny/ArrowLinen.asp)

Prepared for NYSERDA by:  
CDH Energy Corp.  
Cazenovia, NY 13035  
315-655-1063  
[www.cdhenergy.com](http://www.cdhenergy.com)  
[dgchp\\_data@cdhenergy.com](mailto:dgchp_data@cdhenergy.com)