



New York State Energy Research and Development Authority

Fonda-Fultonville CSD

Engines Provide Electric Independence

DG/CHP Program

Project Profile

Combined heat and power for
Educational Facility



Overview

The Fonda-Fultonville Central School District provides educational services for grades K-12 on a single campus. Operating the facility creates an electric load that can approach 1 MW. Rising energy prices forced the school to consider various energy conservation measures (ECMs) including CHP technologies.

Fonda-Fultonville installed a CHP system configured on four identical, natural gas fueled engine-generator sets. A fifth, large diesel generator provides backup power. The school now generates all of its own electricity and has disconnected from the utility grid.

The Application

Like any other business, schools strive to minimize the cost of incidentals that divert resources from primary needs. Unpredictable increases in energy costs can be particularly disruptive to schools operating on fixed annual budgets. Fonda-Fultonville was particularly sensitive to the cost incurred for electricity and sought means to limit the impact of rising rates.

The district worked with Atlantic Energy Services, Inc., to develop a CHP project that ultimately led to the school becoming independent of the utility grid. This was done through an energy services performance contract that guaranteed Fonda-Fultonville a minimum monetary savings. The resulting plant was configured on multiple engine-generator sets having a combined capacity of 1,320 kW. All of the school's electricity is now generated onsite. Heat recovered from the engines provides seasonal space heating and cooling.

Quick Facts

Location:
Fonda, NY (National Grid)

Installation Date:
March 2004

Operating Experience:
2 years (as of March 2006)

CHP Equipment:
Four 330 kW IC Engines

Generating Capacity:
1,320 kW (excludes backup)

Heat Recovery Application:
Building HVAC

Type of Fuel:
Natural Gas

Annual Utility Savings:
\$200,000 per year (estimated)

Simple Payback:
> 15 years (estimated)



Engine-Generators in Sound Attenuation Enclosures

CHP System and Equipment

Fonda-Fultonville's CHP system is configured on four 330 kW, natural gas fueled engine-generator sets. A separate 1,000 kW diesel generator was installed as backup. The plant operates independent of the utility grid; no electricity is purchased or exported from the site. Automatic controls sequence the operation of each generator and modulate the electrical output to match the load. Waste heat from the engine coolant jackets and exhaust is recovered in a common hot water loop. The heat can be used directly to offset the thermal load on the existing boiler plant or diverted to a 250 ton absorption machine that produces chilled water for air conditioning. Excess heat can be rejected to atmosphere through individual radiators when the school's thermal load is at a minimum.

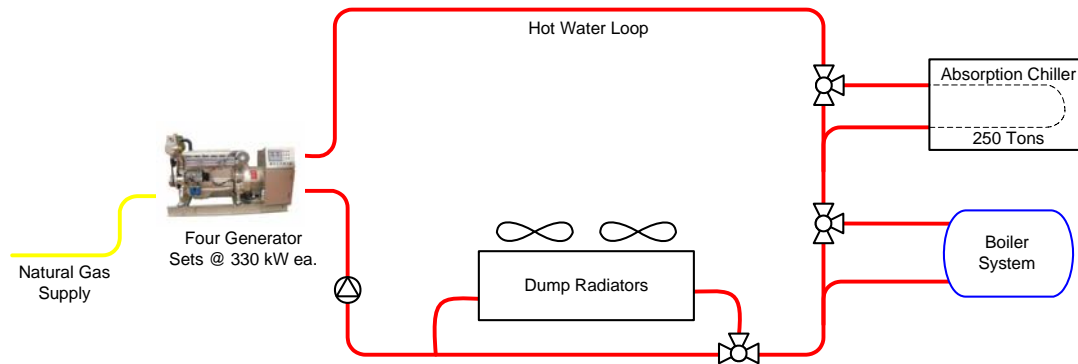

Economics and Environmental Benefits

Hourly data have been collected from the site since August 2007 and are available on NYSERDA's DG/CHP web site. The system will produce approximately 2 million kWh annually and save the school \$200,000 or more. Other ECMs (lighting and HVAC retrofits) implemented coincidentally by Atlantic Energy Services may increase the savings to \$300,000 per year. A 13 year payback is expected on Fonda-Fultonville's expenditure in the combined measures. The greater efficiency of the CHP system should yield a significant reduction in carbon dioxide emissions as compared to using separate purchased electric and thermal utilities to provide the same service.



Exhaust Heat Recovery Unit at rear of Engine



Absorption Chiller Provides Air Conditioning

Summary of Benefits

- Grid independence isolates school from electric rate increases
- Savings guarantee provided by project developer
- Recovered heat used year-round to provide building HVAC

“This state-of-the-art CHP facility will serve as a model for school districts throughout the state.”

- Assemblyman Paul Tonko

Web Links and Further Information:

Atlantic Energy Services, Inc. – Developer

www.atlanticenergy.net

Engine Manufacturer

www.cumminspower.com

Other DG/CHP Resources

chp.nyserda.org

www.nrg-concepts.com

Prepared for NYSERDA by:
CDH Energy Corp.
Cazenovia, NY 13035
315-655-1063
www.cdhenergy.com
dgchp_data@cdhenergy.com