



New York State Energy Research and Development Authority

River Point Towers

Generators Serve Multiple Heat Loads

DG/CHP Program

Project Profile

Combined heat and power for
Apartment Building



Overview

River Point Towers is a 412 unit residential building located in Bronx, NY. Peak summer electrical demands typically approached 600 kW. Natural gas use was high year round due to the operation of a steam driven absorption chiller.

Five 75 kW engine-generator sets were recently installed at the site to produce electricity and hot water. The generators will provide about 70% of the site's electricity. Heat recovered from the engines offsets steam used for space heating and DHW production. Excess heat can be diverted to an outdoor swimming pool or a cooling tower depending on the season.

The Application

River Point operates as a cooperative which gives the residents an acute sense of the costs involved maintaining the facility and related services. All of the building's utilities are centrally distributed; electricity is metered at a single entrance. Two steam boilers provide heat to separate hot water loops used for space heating and DHW. A steam driven absorption chiller used for air conditioning was causing fuel consumption to peak in summer.

Because of these circumstances, River Point chose to install a CHP system; technology that could impact all of the utility services. River Point worked with American DG Energy who took ownership of the equipment and responsibility for its ongoing maintenance and operation. Five 75 kW Tecogen CHP modules were installed along with a 200-ton engine driven chiller that should curtail use of the absorption machine.



Single CHP Module Shown During Installation

Quick Facts

Location:
Bronx, NY (Con Edison)

Installation Date:
May 2004

Operating Experience:
8 months (as of October 2008)

CHP Equipment:
Five 75 kW IC Engines

Generating Capacity:
375 kW

Heat Recovery Application:
Space Heating, Domestic Hot Water and Pool (2,840 MBtu/h peak)

Design CHP Efficiency:
72% HHV

Type of Fuel:
Natural Gas

Annual Utility Savings:
\$264,000 per year (estimated)

Simple Payback:
4.1 years (estimated)

CHP System and Equipment

The CHP system is configured around five 75 kW natural gas fired engine-generator sets. Electricity is produced in parallel with the utility grid; the output can be modulated to follow the thermal or electric load. The latter scheme will be employed during the utility's designated on-peak periods. Waste heat from the engine jackets and exhaust is recovered as 230°F hot water that is circulated through a series of heat exchangers on the return side of the space heating and DHW distribution systems thus reducing the existing boiler's fuel consumption. The resulting piping arrangement gives priority to the thermal loads in the order shown. Any excess heat can be diverted to an outdoor pool or rejected through a cooling tower installed with the new chiller through a separate heat exchanger dedicated to this purpose.

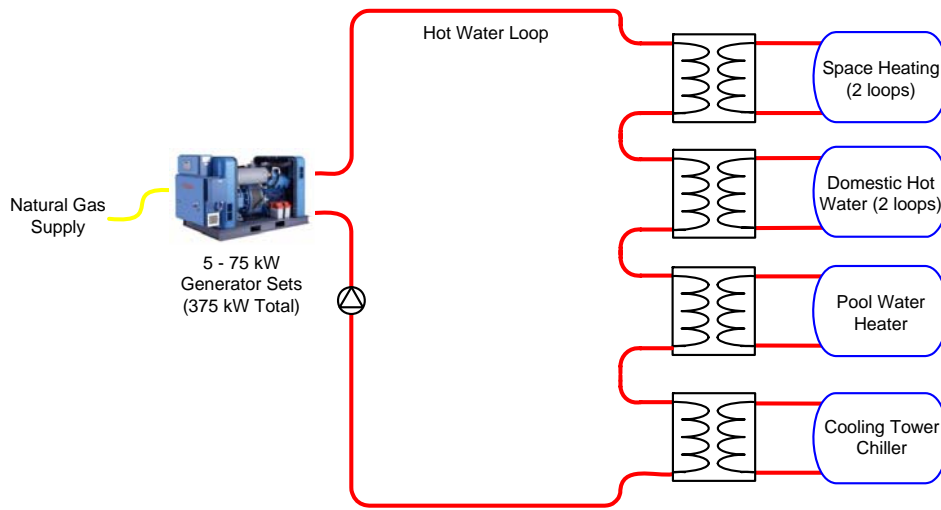

Economics and Environmental Benefits

Monitored data are being collected from the site and are available in an hourly format on NYSERDA's DG/CHP website starting from March 2008. The CHP system should reduce the consumption of utility purchased electricity by almost 2 million kWh annually and the average demand by 240 kW. A payback period of 4.1 years is expected based on estimated annual energy savings of \$264,000 operating at a peak efficiency of 72% HHV. The greater efficiency of the CHP system as compared to using separate electric and thermal utilities should yield significant reductions in carbon dioxide emissions.



Exhaust Heat Recovery Heat Exchanger



Heat Exchanger Network Serving End Uses

Summary of Benefits

- Multiple CHP modules provide redundancy
- Recovered heat serves multiple end uses
- Priority of heat recovery determined by heat exchanger piping arrangement

“With the dramatic increase in fuel and electricity costs, installing this cogeneration facility represents our greatest single opportunity for cost savings in the cooperative's budget.”

- Linda Lebnsold,
President, River Point
Towers Cooperative,
Inc.

Web Links and Further Information:

AmericanDG
Energy –
Developer/Engineer

www.americandg.com

Equipment
Manufacturer

www.tecogen.com

Other
DG/CHP
Resources

chp.nyserda.org

Prepared for NYSERDA by:
CDH Energy Corp.
Cazenovia, NY 13035
315-655-1063
www.cdhenergy.com
dgchp_data@cdhenergy.com

