



New York State Energy Research and Development Authority

Rochester Airport

CHP Plant Provides Building HVAC

DG/CHP Program

Project Profile

Combined heat and power for
International Airport



Overview

The Greater Rochester International Airport (GRIA) is operated by Monroe County on the west side of the city. The county strives to maximize the benefits it provides local taxpayers. Reducing energy costs is one of the myriad ways the county seeks to fulfill that goal.

At GRIA this was achieved by installing two 750 kW engine-generators that produce about 90% of the site's electricity. Hot water recovered from the engines provides seasonal heating and cooling at an overall efficiency that can exceed 80% HHV on the coldest days of the year.

Quick Facts

Location:
Rochester, NY (RG&E)

Installation Date:
June 2002

Operating Experience:
3.5 years (as of January 2006)

CHP Equipment:
Two Waukesha 750 kW Engine-Generator Sets

Generating Capacity:
1,500 kW

Heat Recovery Application:
Building HVAC

Design CHP Efficiency:
>80% HHV (Winter Peak)

Type of Fuel:
Natural Gas

Annual Utility Savings:
\$334,000 per year (estimated)

Simple Payback:
9.4 years (estimated)

The Application

GRIA originally used conventional HVAC systems to provide space heating and cooling. The electrical demand exceeded 2 MW in summer when cooling was required while heating fuel consumption was the dominated energy use in winter. The county worked with Siemens Building Technologies, Inc., to implement a number of energy conservation measures (ECMs) at the site. This was done through an energy services performance contract that guaranteed the county a minimum level of monetary savings.

Siemens installed two 750 kW generators that currently produce most of the airport's electricity and serve as backup in the event of a blackout. Heat recovered from the engines is used to offset both space heating and cooling loads. Energy consumption at the airport has been reduced almost 50% because of the combined effect of the CHP system and other ECMs.



750 kW Engine Generating Set During Installation

CHP System and Equipment

GRIA's CHP system is configured on two 750 kW, natural gas fueled engine-generator sets. The generators and related ancillaries were pre-packaged on separate skids to facilitate connection with the independent feeders that serve the airport's east and west concourses. Electricity is produced in parallel with the local utility. The generators' output is modulated to follow the site load; no electricity is exported to the grid. Both units are equipped with synchronous generators and can supplant use of the normal emergency power systems. Heat is recovered from each engine as hot water that can be used for spacing heating or circulated through an absorption machine to produce chilled water for air conditioning. Excess heat is rejected to atmosphere through radiators included on the equipment skids.

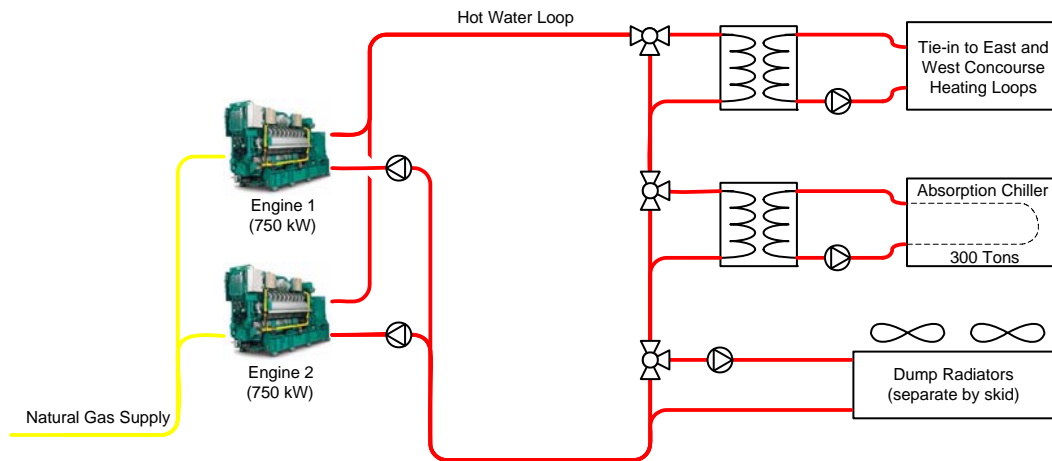

Economics and Environmental Benefits

GRIA is guaranteed annual savings of \$500,000 for all of the ECMs implemented through the contract with Siemens. This ensures the county's \$2 million capital outlay will be recovered within ten years. However, payback is likely to be achieved in less time as energy prices continue to escalate. Carbon dioxide emissions should be reduced by 2,260 tons annually due to the greater overall efficiency of the CHP system compared to the conventional operation. Monitored data are being collected from the site and are available in an hourly format on NYSERDA's DG/CHP website starting from July 2006.



Installed View of Absorption Chiller



Generator Package Outside Concourse

Summary of Benefits

- Modular system provides redundancy and reliability
- Absorption chiller offsets additional summer peak electrical loads
- Economic performance guaranteed by project developer

“This partnership has been a positive experience that met our expectations to produce energy and reduce costs.”

- Maggie Brooks,
Monroe County
Executive

Web Links and Further Information:

Siemens Building
Technologies –
ESCO

www.siemens.com

Equipment Manufacturer

www.waukeshaengine.com

Other DG/CHP Resources

chp.nyserda.org

www.rocairport.com

Prepared for NYSERDA by:
CDH Energy Corp.
Cazenovia, NY 13035
315-655-1063
www.cdhenergy.com
dgchp_data@cdhenergy.com